

Adding a second Wireless TV Receiver

- A. Complete the installation of the first Wireless Receiver.
- B. Repeat steps 2 and 3 in this guide with the second Wireless Receiver.

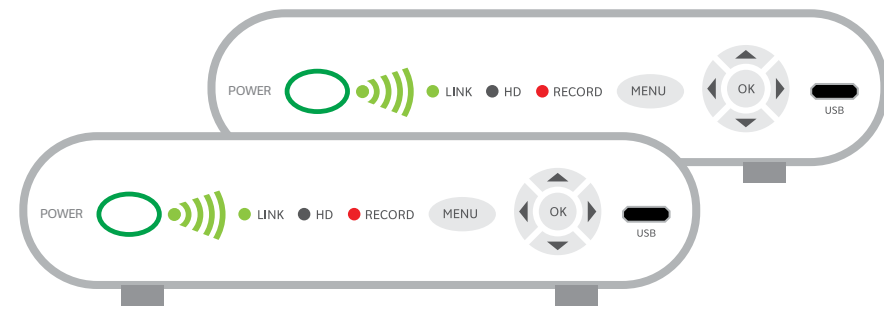

Visit att.com/wirelessTV or scan the QR code



Download and install the free AT&T Code Scanner on your mobile phone at <http://scan.mobi> or your app store.

From there you can:

- View help videos
- Chat online with a technician
- Easily find troubleshooting information and user guides
- Learn how to return this product

If that doesn't do it, go to Channel 411 to watch a helpful video or give us a call at 800.288.2020 and ask for "U-verse technical support." We can help you with that!

Questions?

Go online: Visit att.com/uversesupport

¿Hablas español? Por favor visita att.com/uverseguias para ver la información en español. También puedes ver la siguiente guía: ATT110900769-9 (Wireless TV Receiver) para más detalles.

Important legal information regarding your Wireless Receiver: Additional fee(s) may apply. Wireless from the Wireless Access Point to the Wireless Receiver; power outlet and separate connection of Wireless Receiver to TV is required. For residential use in a single household only. Limit two Wireless Receivers per household. Actual range of wireless signal will vary and may be limited by several factors including, but not limited to, electromagnetic interference, home construction material, obstructions, and other environmental factors. The installation and use of the Wireless Receiver is subject to the AT&T U-verse Terms of Service that can be found at att.com/u-verse/att-terms-of-service.jsp.



AT&T U-verse



Wireless TV Receiver self-installation guide

Important!

Do not attempt to install your new Wireless TV Receiver until **2pm or later** on your service activation date. You can find this date on your packing slip.



Packing slip

Ready to install your U-verse Wireless TV Receiver?

Let's get started

Average installation time: 20 minutes

What's in the box?

To install your Wireless Receiver, you will need:

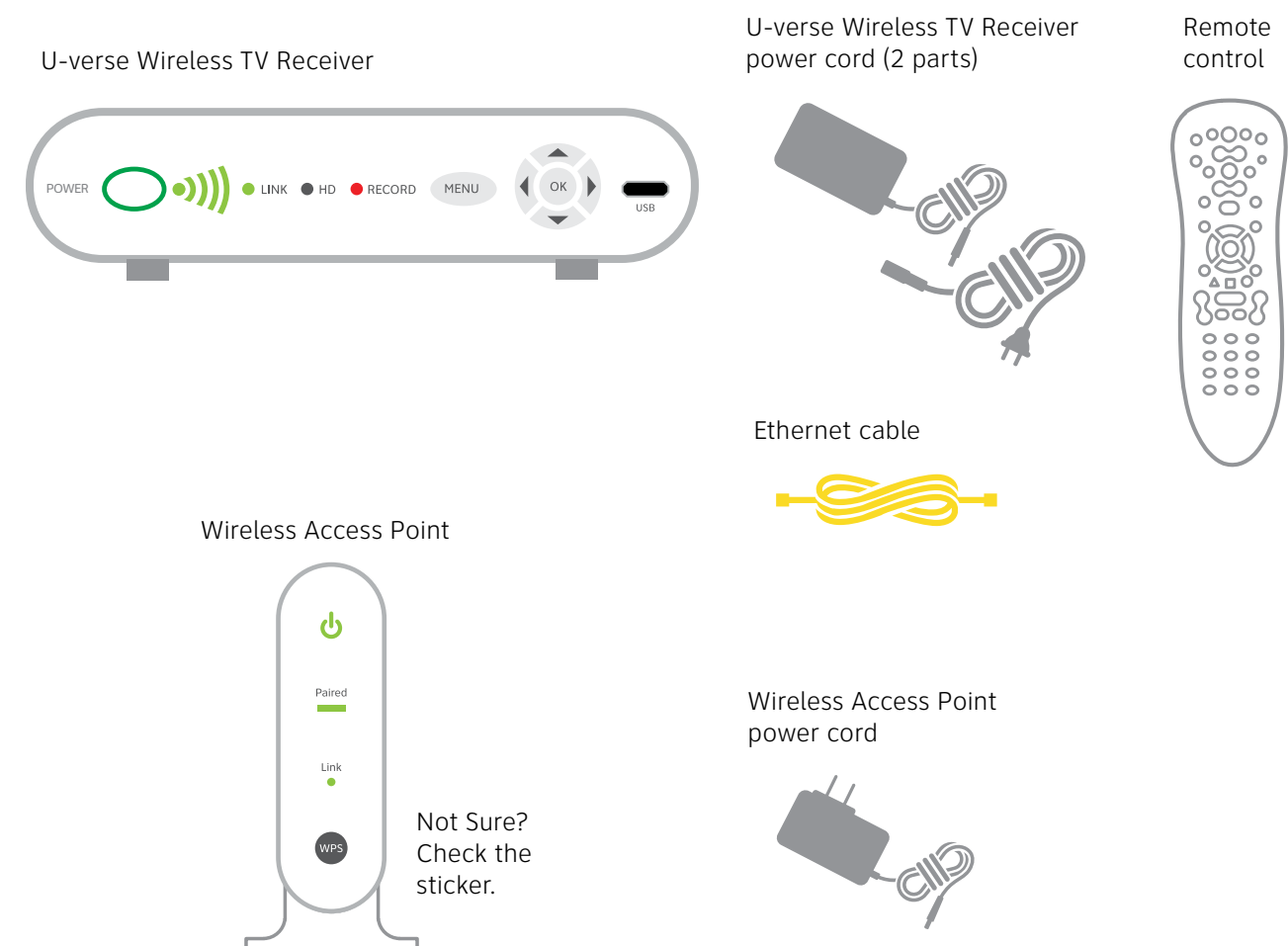

What else do you need?

Your existing Wi-Fi Gateway (actual model may vary)

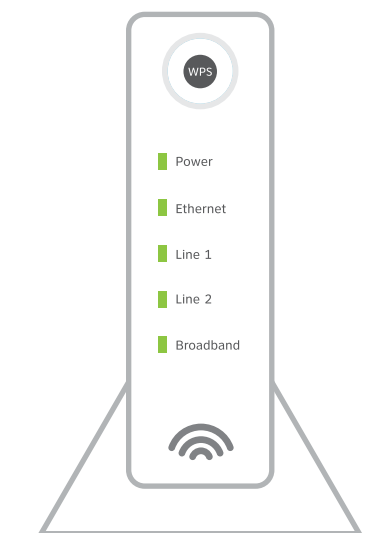

HDMI, Component, Composite, or Coaxial cabling (not included)

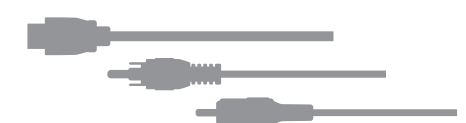

Note: Additional cable(s) (HDMI, RCA, Coaxial, etc.) that connects TV with U-verse Wireless Receiver not included.



ATT110900769-9

1. Set up the Wireless Access Point

First you need to connect your existing Wi-Fi Gateway to the Wireless Access Point.

Note: If you are adding a second Wireless TV Receiver, skip this step and go to step 2.

- A. Connect the Wireless Access Point to your existing Wi-Fi Gateway using the yellow Ethernet cable.
- B. Move the Wireless Access Point as far away from the Wi-Fi Gateway as possible.
- C. Use the power cord to plug the Wireless Access Point into a working electrical outlet.

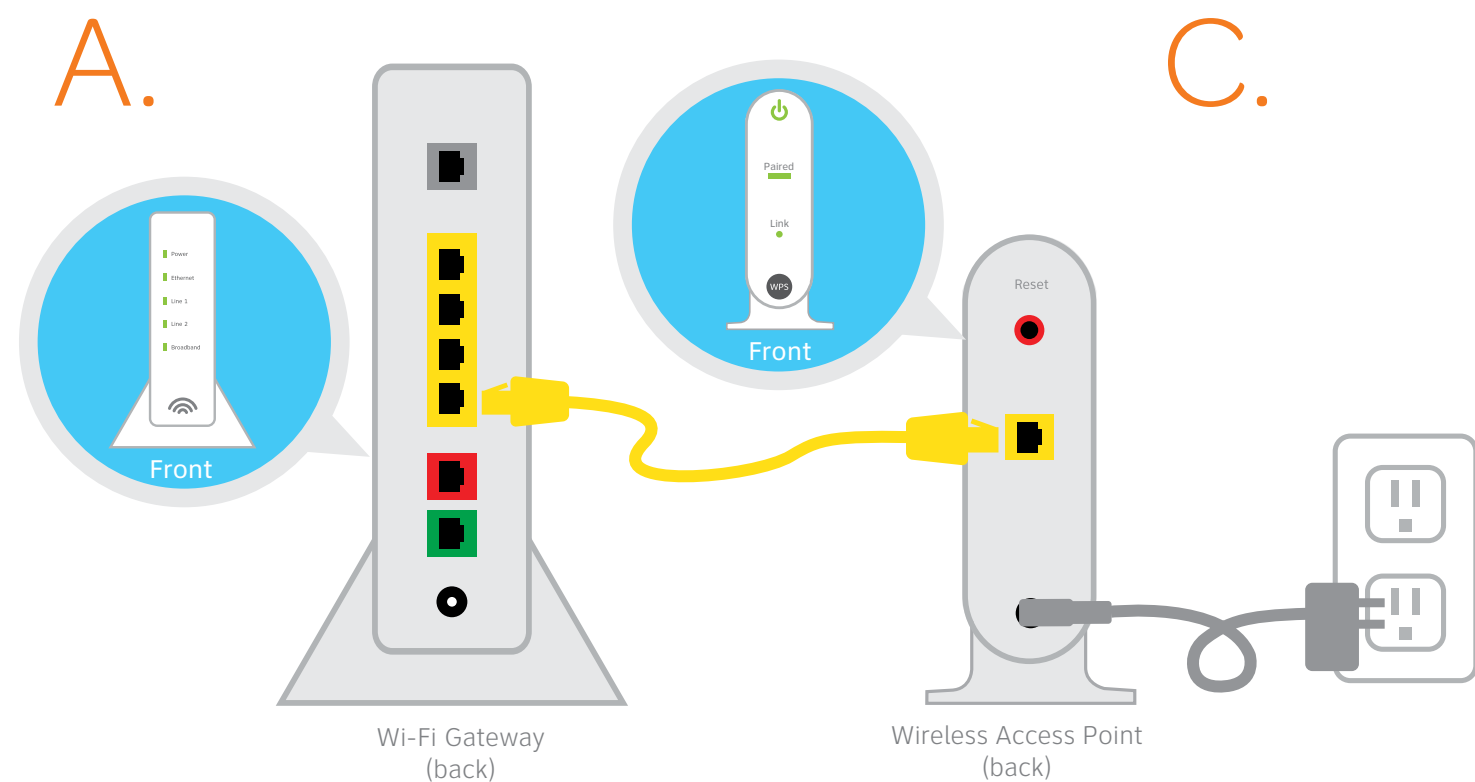

Remember:

Make sure you have an open Ethernet port on your existing Wi-Fi Gateway, and be sure to leave existing cables plugged in. No open port? You'll need to purchase an Ethernet hub with additional ports.

2. Set up the Wireless TV Receiver

The next step is to connect your Wireless TV Receiver to your TV.

- A. Connect the Wireless TV Receiver to your TV with an HDMI cable (**not included**). You may also use Component or Coaxial cables.
- B. Power up your TV. Select the connection type you used in Step 2A. For instance, if you used an HDMI cable, select HDMI. You may need to consult your TV user manual to locate the Input/Source screen. Your TV manufacturer's remote control may have an Input/Source button that will take you there.
- C. Put the two-part power cord together. Then use it to plug the Wireless TV Receiver into an electrical outlet and it will power up automatically. After about a minute, you'll receive additional onscreen instructions.

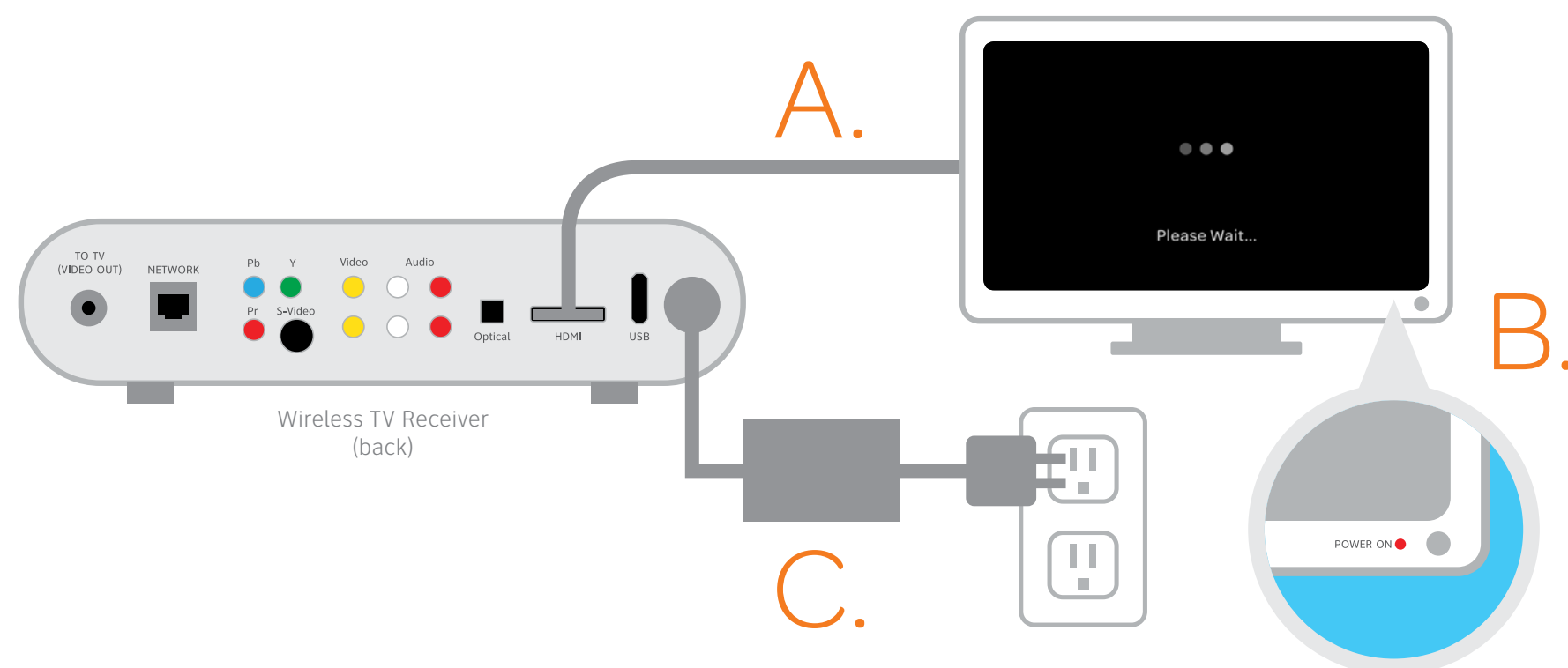

3. Pair up

Now let's get your Wireless TV Receiver talking to the Wireless Access Point. Follow the instructions below.

- A. Press the WPS button on your Wireless Access Point.



Follow the instructions in Step 3A (to the left). Your TV screen should look like this.

- B. On the front of your new Wireless TV Receiver, press the OK button within two minutes.

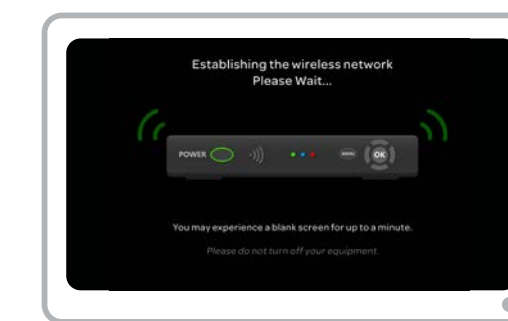
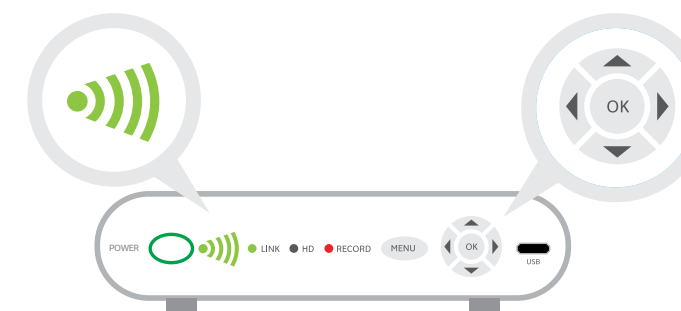

Your TV screen should look like this.

Note: Pairing occurs quickly. To ensure you have proper signal strength, there should be at least three green LED bars lit up on the Wireless TV Receiver.

- C. When you see a green LED on the front of your Wireless TV Receiver, you've paired successfully. It may then take a few more minutes before live TV appears.

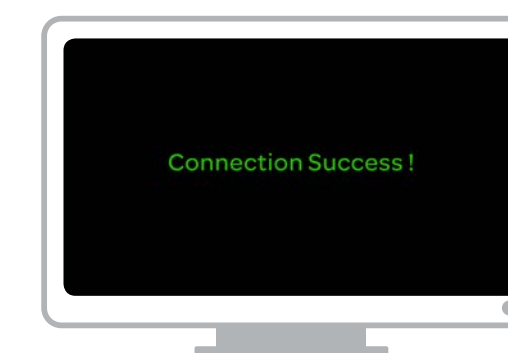
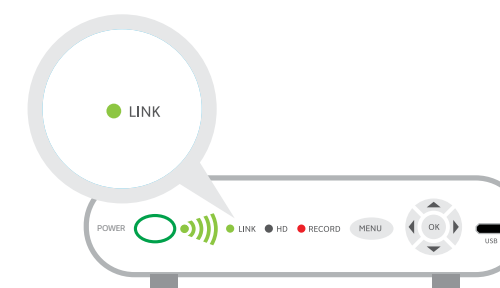

Your TV screen should look like this.

Nicely done. Now it's time to enjoy U-verse TV.

Need help programming your remote control?



- Press **MENU** on your remote. Go to **Help > Remote Control Setup**
- See the user guide packaged with the remote control
- Go to att.com/uverseremote
- See instructions on the inside of the remote control battery cover

Having trouble?

If you see a connection error:

1. Press and hold the power button for 10 seconds to restart the Wireless TV Receiver and repeat the connection process.
2. Disconnect your Wireless TV Receiver from its current location. Move it closer to the Wi-Fi Gateway. Plug the Wireless TV Receiver into an electrical outlet and reconnect it to a TV.
3. Give it a minute and then repeat step 3 (Pair up).

For more help, visit att.com/wirelessTV or go to Channel 411 on your TV to watch a helpful video.

