



AT&T All-Fi[®] Hub (BGW830)

What do the lights mean?

Complete guide to the information the LED lights on your AT&T All-Fi Hub provide.



Panel diagram

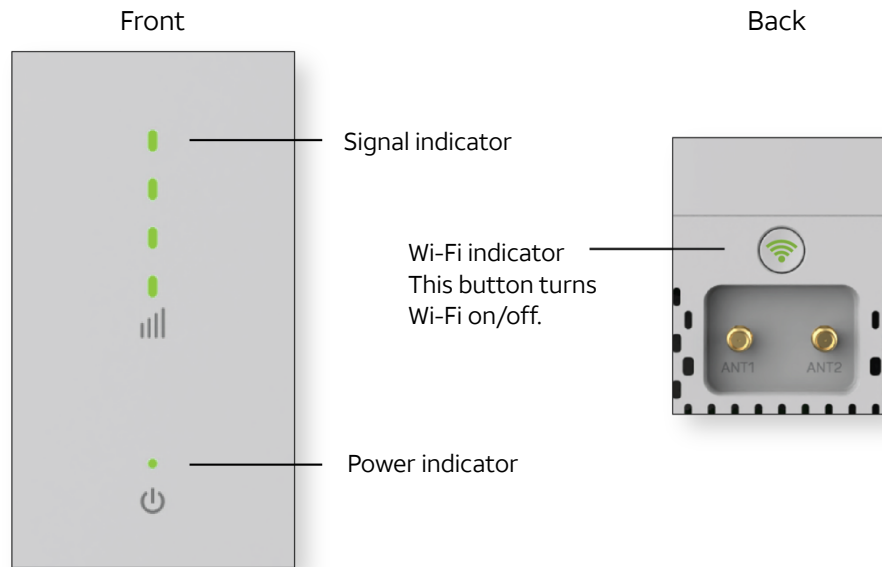

LED indicators

All-Fi Hub LEDs	Color	Meaning
	Off	
	Off	Your All-Fi Hub is starting up
	Off	
	Off	
	Solid green	Power is on
	Solid green	Wi-Fi is on
	Chasing amber LEDs	As your All-Fi Hub powers up or resets, it presents a chasing amber LED animation. This means it's searching for the best signal tower for your service. Please stand by.
	Chasing amber LEDs	
	Solid green	
	Solid green	

LED indicators—signal status

All-Fi Hub LEDs	Color	Meaning
	Off Off Off Solid green	You have a poor signal . Your All-Fi Hub's status lights will show 1 green LED. You will need to move the All-Fi Hub to a better location where you get 3 or 4 green LEDs.
	Off Off Solid green Solid green Solid green Solid green	You have a low signal . Your All-Fi Hub's status lights will show 2 green LEDs. You will need to move the All-Fi Hub to a better location where you get 3 or 4 green LEDs.
	Off Solid green Solid green Solid green Solid green Solid green	You have a great signal . Your All-Fi Hub's status lights will show 3 green LEDs. You can activate your All-Fi Hub with this signal strength or higher.
	Solid green Solid green Solid green Solid green Solid green Solid green	You have the best signal . Your All-Fi Hub's status lights will show 4 green LEDs. You can activate your All-Fi Hub with this signal strength.

LED indicators

All-Fi Hub LEDs	Color	Meaning
	Solid green Solid green Solid green Solid green Solid green	Normal state
	Solid green Solid green Solid green Solid green Blinking amber Solid green	Your All-Fi Hub is performing an Update. Please wait until the hub reboots and comes back online. Do not unplug power or reboot.
	Blinking green Blinking green Blinking green Blinking green Blinking green Blinking green	Your All-Fi Hub is going through a factory reset. Please wait while it starts back up.
	Solid green Solid green Solid green Solid green Off Solid green	Wi-Fi is off

Error LED patterns

Your All-Fi Hub displays error LEDs. Check the AT&T Internet Air® error codes FAQ to find out what the error code on your hub means and how to fix it.

All-Fi Hub LEDs	Color	Meaning
	Blinking amber Off Off Off Solid green Solid red	E004. No IP address from network.
	Blinking amber Blinking amber Off Off Solid green Solid red	E400. SIM error.
	Blinking amber Blinking amber Blinking amber Off Solid green Solid red	E403. Wireless 5G/LTE authentication failure.

Error LED patterns (continued)

Your All-Fi Hub displays error LEDs. Check the AT&T Internet Air® error codes FAQ to find out what the error code on your hub means and how to fix it.

All-Fi Hub LEDs	Color	Meaning
	Blinking amber Blinking amber Blinking amber Blinking amber Solid green Solid red	E013. DNS down.
	Off Off Off Off Solid green Solid red	E405. Wireless 5G/LTE connection not detected.
	Off Off Off Off Solid green Solid green	E009. High temp warning. If this occurs but the device is not restarting or has not recently been moved, this could indicate the device may be overheating. Try unplugging the device to allow it to cool or relocate it away from any heat or sunlight.

Additional LED indicators

All-Fi Hub LEDs	Color	Meaning
	Off	Your All-Fi Hub has no power. Check power supply.
	Off	
	Off	
	Off	
	Off	
	Off	

Back panel

