



Sony Ericsson

User guide
W600i



This is the Internet version of the user's guide. © Print only for private use.

Contents

Getting Started	7	Connectivity	59
Assembly, SIM card, battery, turning on, startup menu, calls.		Internet and email settings, synchronizing, Bluetooth, infrared, USB cable, update service.	
Getting to Know Your Phone	12	More Features	67
Phone overview, icons, use the menus, entering letters, file manager.		Alarm clock, calendar, tasks, profiles, time and date, SIM card lock, etc.	
Calling	21	Troubleshooting	74
Calls, contacts, voice control, call options.		Why doesn't the phone work the way I want?	
Messaging	34	Important Information	79
Text messaging, picture messaging, voice messaging, email, My Friends.		Sony Ericsson Consumer Web site, safe and efficient use, warranty, declaration of conformity.	
Imaging	44	Index	88
Camera, video recorder, pictures.			
Entertainment	48		
WALKMAN™, radio, PlayNow™, ringtones, MusicDJ™, VideoDJ™, games and more.			

Sony Ericsson

GSM 850/900/1800/1900

This user guide is published by Sony Ericsson, without any warranty. Improvements and changes to this user guide necessitated by typographical errors, inaccuracies of current information, or improvements to programs and/or equipment, may be made by Sony Ericsson at any time and without notice. Such changes will, however, be incorporated into new editions of this user guide.

All rights reserved.

©Sony Ericsson Mobile Communications AB, 2005

Publication number: AE/LZT 123 1785 R1A

Please note:

Some of the services in this user guide are not supported by all networks. *This also applies to the GSM International Emergency Number 112.*

Please contact your network operator or service provider if you are in doubt whether you can use a particular service or not.

Please read the *Guidelines for safe and efficient use* and the *Limited warranty* chapters before you use your mobile phone.

Your mobile phone has the capability to download, store and forward additional content, e.g. ringtones. The use of such content may be restricted or prohibited by rights of third parties, including but not limited

to restriction under applicable copyright laws. You, and not Sony Ericsson, are entirely responsible for additional content that you download to or forward from your mobile phone. Prior to your use of any additional content, please verify that your intended use is properly licensed or is otherwise authorized. Sony Ericsson does not guarantee the accuracy, integrity or quality of any additional content or any other third party content. Under no circumstances will Sony Ericsson be liable in any way for your improper use of additional content or other third party content.

The Bluetooth word mark and logos are owned by the Bluetooth SIG, Inc. and any use of such marks by Sony Ericsson is under license.

The marble logo, Style-Up, QuickShare, PlayNow, MusicDJ, PhotoDJ and VideoDJ are trademarks or registered trademarks of Sony Ericsson Mobile Communications AB.

WALKMAN and the WALKMAN logo and symbol are registered trademarks of Sony Corporation.

Microsoft, Windows and PowerPoint are either registered trademarks or trademarks of Microsoft Corporation in the U.S and other countries.

Mac OS is a trademark of Apple Computer, Inc., registered in the U.S. and other countries.

T9™ Text Input is a trademark or a registered trademark of Tegic Communications.

T9™ Text Input is licensed under one or more of the following: U.S. Pat. Nos. 5,818,437, 5,953,541, 5,187,480, 5,945,928, and 6,011,554; Canadian Pat. No. 1,331,057, United Kingdom Pat. No. 2238414B; Hong Kong Standard Pat. No. HK0940329; Republic of Singapore Pat. No. 51383; Euro.Pat. No. 0 842 463(96927260.8) DE/DK, FI, FR, IT, NL, PT, ES, SE, GB; and additional patents are pending worldwide.

Java and all Java based trademarks and logos are trademarks or registered trademarks of Sun Microsystems, Inc. in the U.S. and other countries.

End-user license agreement for Sun™ Java™ J2ME™.

- 1** Restrictions: Software is confidential copyrighted information of Sun and title to all copies is retained by Sun and/or its licensors. Customer shall not modify, decompile, disassemble, decrypt, extract, or otherwise reverse engineer Software. Software may not be leased, assigned, or sublicensed, in whole or in part.
- 2** Export Regulations: Software, including technical data, is subject to U.S. export control laws, including the U.S. Export Administration Act and its associated regulations, and may be subject to export or import regulations in other countries. Customer agrees to comply strictly with all such regulations and acknowledges that it has the responsibility to obtain licenses to export, re-export, or import Software. Software may not be downloaded, or otherwise exported or re-exported (i) into, or to a national

or resident of, Cuba, Iraq, Iran, North Korea, Libya, Sudan, Syria (as such listing may be revised from time to time) or any country to which the U.S. has embargoed goods; or (ii) to anyone on the U.S. Treasury Department's list of Specially Designated Nations or the U.S. Commerce Department's Table of Denial Orders.

- 3** Restricted Rights: Use, duplication or disclosure by the United States government is subject to the restrictions as set forth in the Rights in Technical Data and Computer Software Clauses in DFARS 252.227-7013(c) (1) (ii) and FAR 52.227-19(c) (2) as applicable.

Part of the software in this product is copyright © SyncML initiative Ltd. (1999-2002). All rights reserved.

Other product and company names mentioned herein may be the trademarks of their respective owners. Any rights not expressly granted herein are reserved.

PlayNow™ Terms and Conditions (T&C)

Your mobile phone has PlayNow™, a unique entertainment service from Sony Ericsson. With PlayNow, you can, for example, listen to music tones before you download them to your phone. In some countries/regions you may be able to purchase e.g. music tones from some of the world's top musical artists ("Purchase").



PlayNow may not be available in all countries/regions.

PlayNow is a trademark or a registered trademark of Sony Ericsson Mobile Communications AB.

PlayNow is a service provided by Sony Ericsson Mobile Communications (USA) Inc. (in the U.S.), and which allows you to download e.g. music tones ("Content") to your Sony Ericsson product.

If you want to get in contact with Sony Ericsson, please go to the Contact Us section at the general Sony Ericsson web page (www.sonyericsson.com) or call our local customer care center.

Please note that Sony Ericsson may use an agent or partner for the purposes of billing, ordering and delivering Content.

Right to download and Purchase the Content will give you the right to use the Content exclusively for your own personal use. No license is granted to you with respect to the human-readable source code for any Content and no rights are sold, transferred or otherwise

conveyed with respect to any Sony Ericsson or its content providers patents, copyrights, trade marks, trade secrets or other intellectual property rights.

User Requirements

To Purchase Content you must be at least 18 years old or receive your parent's or guardian's consent.

When using PlayNow, you hereby accept and agree to the following: (i) You will follow the user instructions you have been and will be presented with during the entire use of PlayNow; (ii) Your Sony Ericsson product must support the technical requirements, if applicable; (iii) You may not initiate the PlayNow client without the Sony Ericsson product being sufficiently charged; and (iv) To the fullest extent permitted by law, neither Sony Ericsson nor its content providers can be held responsible for any damage or loss of other software or hardware of your Sony Ericsson product resulting from the use of PlayNow.

Payment Terms

You hereby agree and accept to use PlayNow and when applicable Purchase Content for which you will be charged the amount appearing in your phone display and the service provider charge for sending a text message. The total cost for the Premium SMS (a payment mechanism automatically generating one or more text message(s) once you have accepted the Purchase) will be charged to your mobile phone

bill or to your pre-paid phone card. Further payment terms will be determined by your subscription agreement with your service provider.

The cost for your connection to the PlayNow client via GPRS to download the Content is incremental and not included in the approximate price quoted in the phone display.

Cancellation and Withdrawal

Once you have accepted a price quoted in the phone display along with these terms and conditions you have confirmed your Purchase and cancellation is not possible. Please note that by accepting the Purchase in the phone display you have implicitly consented that your order for services will be performed by Sony Ericsson prior to the end of the usual period for the right for withdrawal and since the services by their nature can not be returned to Sony Ericsson, you will not be entitled to exercise your right to withdraw.

Content

The Content is owned by Sony Ericsson or Sony Ericsson's Content providers. You may download the Content exclusively for your own, personal use. Content may not be modified, altered or distributed.

Warranty Disclaimer and Limitation of Liability

CONTENT IS PROVIDED "AS IS" AND TO THE FULLEST EXTENT PERMITTED BY LAW SONY ERICSSON AND ITS CONTENT PROVIDERS SPECIFICALLY DISCLAIM ANY WARRANTY OR CONDITION WHATSOEVER REGARDING MERCHANTABILITY, FITNESS FOR A SPECIFIC PURPOSE, TITLE OR NON-INFRINGEMENT. TO THE FULLEST EXTENT PERMITTED BY LAW SONY ERICSSON ALSO DISCLAIMS ALL WARRANTIES WITH REGARD TO WHETHER THE CONTENT WILL MEET YOUR INDIVIDUAL REQUIREMENTS, WORK IN COMBINATION WITH ANY HARDWARE OR SOFTWARE OR OPERATE ON AN UNINTERRUPTED OR ERROR FREE BASIS. IN NO EVENT WILL SONY ERICSSON'S LIABILITY FOR ANY CLAIM RELATING TO THE CONTENT OR ITS USE, WHETHER IN CONTRACT, TORT, OR OTHERWISE, EXCEED THE AMOUNTS PAID BY YOU FOR SUCH CONTENT. IN NO EVENT WILL SONY ERICSSON BE LIABLE FOR ANY CONSEQUENTIAL, INCIDENTAL, SPECIAL, PUNITIVE, EXEMPLARY OR STATUTORILY MULTIPLE DAMAGES OF ANY KIND ARISING OUT OF YOUR PURCHASE, ATTEMPTED USE OR USE OF THE CONTENT. THE ABOVE LIMITATIONS ONLY APPLY TO THE GREATEST EXTENT PERMITTED BY LAW. NOTHING IN THESE TERMS AND CONDITIONS LIMIT YOUR STATUTORY

RIGHTS AS A CONSUMER. PLEASE NOTE THAT YOUR PERSONAL SETTINGS AND/OR DOWNLOADS MAY BE LOST WHEN YOUR SONY ERICSSON PRODUCT IS REPAIRED OR REPLACED. WITH RESPECT TO THE OPERATION OF PLAYNOW, IN NO EVENT SHALL SONY ERICSSON BE LIABLE FOR ANY USER ERROR, OR FOR THE AVAILABILITY, FAILURE OR NON-PERFORMANCE OF THE NETWORK SERVICE ON WHICH THE SONY ERICSSON DEVICE OPERATES.

Support

Sony Ericsson and its agents or representatives hereby reserve the right to refer the consumer to the relevant service provider if the reason for the error is exclusively due to non-availability or non-functionality of the service provider's services. In the event Sony Ericsson is required under law to remedy any failed delivery of a PlayNow content, Sony Ericsson's sole obligation to you, as determined in its absolute discretion shall be to repair or replace the Content. If, in Sony Ericsson's discretion such repair or replacement cannot be performed, Sony Ericsson will provide a refund in the amount of or your payment for the content. Sony Ericsson reserves the right to charge you a reasonable handling fee where the error may be attributed to you and/or your non compliance with all instructions applicable to PlayNow, including without limitation what is stated herein and in the phone display.

Access to PlayNow and Limitation

Sony Ericsson may change, modify or withdraw access to PlayNow at any time, including its services, without prior notice, and without any liability whatsoever. Sony Ericsson is not liable for the temporary non-availability of PlayNow, or for any delay or damage during the transmission. To the fullest extent permitted by law, no warranty of any kind is made in relation to the condition, suitability, availability, accuracy, reliability, merchantability and/or non-infringement of PlayNow or Content provided through the service, the user's own equipment, any public communication and/or service provider networks or that provision of this PlayNow or the services will be uninterrupted or error-free.

Export

The Content may be subject to applicable export control laws. You agree to obey all such laws and regulations with respect to your possession and use of the Content.

Dispute Resolution

Any controversy arising out of Sony Ericsson's provision of the Content or your use or attempted use of such Content shall be fully and finally resolved by the courts of your home country. The laws of the state of New York shall apply to the extent permitted by law, without regard to any conflict of law principles.

Getting Started

Assembly, SIM card, battery, turning on, startup menu, calls.

More information and downloads are available at www.SonyEricsson.com.

Instruction Symbols

The following instruction symbols appear in this user guide:



Note



Indicates that a service or function is network- or subscription-dependent. Contact your service provider for details.



Refers to more information on another page.



Use a selection or navigation key to scroll and select  *13 Keys and Buttons*.



Press the navigation key center.



Press the navigation key up.



Press the navigation key down.



Press the navigation key to the left.



Press the navigation key to the right.

Assembly

Before you can use your phone you need to:

- Insert the SIM card.
- Attach and charge the battery.

SIM card and battery information

When you register as a subscriber with a service provider, you get a SIM (Subscriber Identity Module) card. The SIM card contains a computer chip that keeps track of your phone number, the services included in your subscription, and names and numbers in your contacts, among other things.



If you have been using a SIM card in another phone, make sure that your information is saved to the SIM card before you remove it from the other phone. For example, contacts may have been saved in the phone memory.

Getting Started

To insert SIM card and battery

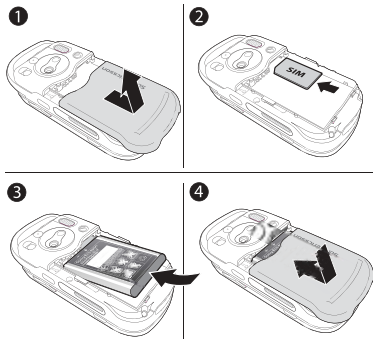

- 1** Remove the battery cover, if attached.
- 2** Insert the SIM card in the slot with the cut off corner first and the gold contacts facing down.
- 3** Place the battery with the label side up and the connectors facing each other. The SIM card will click in place.
- 4** Place and slide the battery cover into place.

To charge the battery

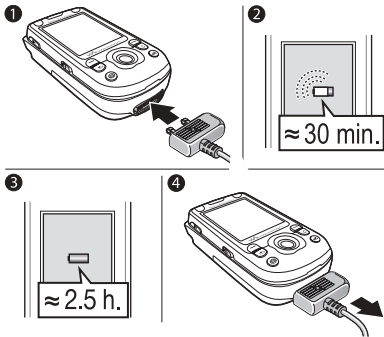

- 1** Connect the charger to the phone. The symbol on the charger plug must face upwards.
- 2** It may take up to 30 minutes before the battery icon appears on the screen.
- 3** Wait approximately 2.5 hours or until the battery icon indicates that the battery is fully charged. Press a key to activate the screen.
- 4** Remove the charger by pulling it out.

To remove the SIM card

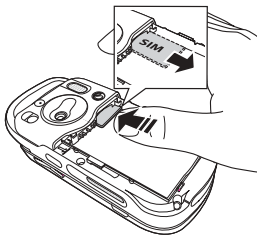

Press the edge of the SIM card to release it from the slot.

PIN

You may need a PIN (Personal Identity Number) to activate the services in your phone. The PIN is associated with your SIM card, and not with the phone. Your PIN is provided by your service provider. When you enter your PIN, each digit appears as *, unless your PIN starts with the same digits as an emergency number, for example 911 or 112. The reason for this is to always let you make emergency calls without entering a PIN.

If you make a mistake while entering your PIN, delete the number by pressing **(C)**.

 If you enter the wrong PIN three times in a row, the SIM card is blocked and the message PIN blocked appears. To unblock it, you need to enter your PUK (Personal Unblocking Key) ➔ 72 SIM Card Lock.

Battery

Some functions use more battery power than others and may cause a need for more frequent re-charging. If talk time or standby time becomes noticeably shorter, you may have to replace the battery.

Only use approved batteries from Sony Ericsson
➔ 82 Battery use and care.

Turning on the Phone and Making Calls

Make sure that the phone is charged and your SIM card is inserted before you turn it on. When you have turned the phone on, you can use the setup wizard to quickly and easily prepare your phone for use.

Getting Started

To turn on the phone



- 1 Press and hold ①. The first startup may take a couple of minutes.
- 2 Select whether you want to use the phone with all functionality or the WALKMAN™ player only ➤ *10 Startup menu*.
- 3 Enter your SIM card PIN, if requested.
- 4 At first startup, select the language you want for your phone menus.
- 5 ▶ **Yes** if you want the setup wizard to help you get started, and follow the instructions that appear. You can start the wizard from the menu system at any time, ▶ **Settings** ▶ the **General** tab ▶ **Setup Wizard**.

To open and close the phone

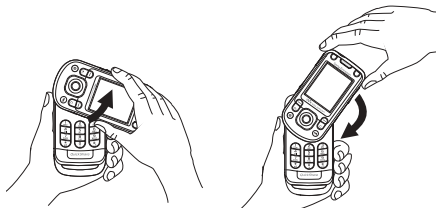

- To open the phone, rotate the top section up until it clicks into place.
- To close the phone, rotate the top section down in the opposite direction.

 *When you open the phone, rotate the top section 180 degrees to the left or right. Do not rotate the top section more than 180 degrees. If you force the top section more than 180 degrees in either direction, the phone will be damaged.*

Startup menu

When the startup menu is activated, each time you turn on the phone, you can select to listen to music only, instead of using the phone with full functionality. This means all transmitters of the phone are turned

off, preventing disturbance of sensitive equipment, for example, in an airplane or in a hospital. You cannot make calls, receive calls, or send messages, etc. You can only use the WALKMAN player. If you have selected **Music Only**, you can still receive calendar and task reminders, and the alarm can still signal.



 *Always follow regulations and any flight crew instructions with respect to onboard use of electronic devices.*

To deactivate the startup menu

- ▶ **Settings** ▶ the **General** tab ▶ **Startup Menu**.
- Select **Don't Show**.

To make and receive calls

You can make and receive calls when the phone is open or closed.

- When open, enter the phone number (with international prefix and area code if applicable) ▶ **Call** to make the call.
▶ **End Call** to end the call.
- When open or closed, ▶ **Contacts** and select the contact to call. Use  or  to select a number ▶ **Call**.

- When the phone rings ▶ **Answer** or ▶ **Busy** to reject the call. This can be done in either open or closed mode.

Stereo Handsfree Headset

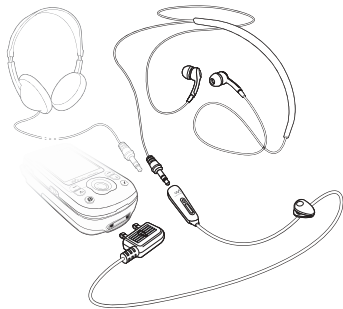

You can connect compatible accessories using a 3.5 mm jack, such as headphones, to your stereo handsfree headset.









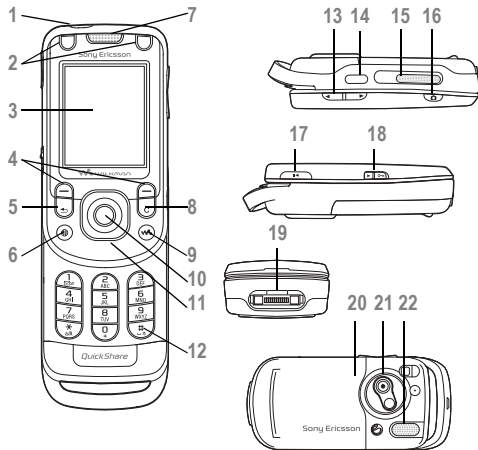



 *You can still answer calls and use the microphone when other compatible accessories are in use.*

Getting to Know Your Phone

Phone overview, icons, use the menus, entering letters, file manager.

Phone Overview



- 1 ① Power on/off button
- 2 Dedicated game buttons
- 3 Screen
- 4  Selection keys
- 5  Back key
- 6  Internet button
- 7 Ear speaker
- 8  Clear key
- 9  WALKMAN™ key
- 10  Navigation key
- 11 Front Style-Up™ Cover
- 12  Silent key
- 13  Volume, camera and picture zoom buttons
- 14  Infrared port, Bluetooth connection
- 15 External speaker
- 16  Camera button
- 17  Play/Pause button
- 18  Lock switch, turn light on/off (camera)
- 19 Stereo headset and charger connector

- 20 Back Style-Up™ Cover
- 21 Camera lens
- 22 External speaker







For more information ➡ *13 Keys and Buttons.*



Navigation

The main menus are shown as icons on the desktop. Some submenus include tabs that appear on the screen. Scroll to a tab by pressing the navigation key left or right and select an option.







Navigating the menus



- Press  (navigation key) to go to the desktop or to select highlighted items.
- Press , , ,  to move through the menus.
- Press ,  to move between the tabs.

- Press  to select options shown immediately above these keys on the screen.
- Press  to go back one level in the menus. Press and hold to return to standby or to end a function.

Keys and Buttons

	Press to delete items, such as pictures, sounds and contacts. During a call, press and hold to mute the microphone.
	Press to open the browser.
	Press to open or minimize the WALKMAN™ player.
	Press to take a picture or to record a video clip.
	Press and hold to launch the WALKMAN player or radio in a minimized mode and press again to close the WALKMAN player or radio.
	Press and hold to call your voicemail service (if set).

Getting to Know Your Phone

2 – **9** Press and hold any of these keys to reach a contact beginning with a specific letter.
Press multiple keys to quickly jump to that specific contact.

1 – **9** Press any of these keys and press **Call** to speed dial.

▲ In standby, press to view status information.
Quickly press twice to reject a call.
Press once to turn off the ringtone when receiving a call.
Press to increase the volume during a call, or when using the WALKMAN player.
Press and hold to go back one track.
When using the camera, press to zoom out.
Press and hold to voice dial, alternatively say your magic word (if set) ➡ *27 Voice Dialing*.

#-0 Press and hold to set the phone to silent. The alarm signals even if the phone is set to silent.
Press once to turn off the ringtone when receiving a call.

▼ In standby, press to view status information.
Quickly press twice to reject a call.
Press once to turn off the ringtone when receiving a call.
Press to decrease the volume during a call, or when using the WALKMAN player.
Press and hold to go forward one track.
When using the camera, press to zoom in.
Press and hold to voice dial, alternatively say your magic word (if set) ➡ *27 Voice Dialing*.

-
- ▶ **Info** Get more information, explanations or tips about selected features, menus or functions available in your phone. Scroll to a menu item ▶ **Info**.
-
- ▶ **More** Enter a list of options. There are different alternatives in the list of options depending on where you are in the menus.

Getting to Know Your Phone

Menu Overview



PlayNow™*



Internet Services*



Entertainment

Online Services*
Games
VideoDJ™
PhotoDJ™
MusicDJ™
Remote Control
Record Sound
Demo Tour



Camera



Messaging

Write New
Inbox
My Friends*
Email
Call Voicemail
Drafts
Outbox
Sent Messages
Saved Messages
Templates
Settings



WALKMAN

Now Playing
Artists
Tracks
Playlists
Videos



File Manager

Pictures
Videos
Sounds
Themes
Web Pages
Games
Applications
Other



Contacts**

Options
Speed Dial
My Business Card
Groups
SIM Contacts
Special Numbers
Advanced
New Contact



Radio



Calls***



All



Answered



Dialed



Missed



Organizer

- Alarms
- Applications
- Calendar
- Tasks
- Notes
- Synchronization
- Timer
- Stopwatch
- Light
- Calculator
- Code Memo



Settings***



General

- Profiles
- Time & Date
- Language
- Update Service
- Voice Control
- Phone Status
- Shortcuts
- Play/Pause Button
- Startup Menu
- Locks
- Setup Wizard
- Tips and Tricks
- Master Reset



Sounds & Alerts

- Ring Volume
- Ringtone
- Silent Mode
- Increasing Ring
- Vibrating Alert
- Open Phone Alerts
- Message Alert
- Key Sound



Display

- Wallpaper
- Themes
- Startup Screen
- Screen Saver
- Brightness
- Sleep Mode Clock
- Edit Line Names*



Calls

- Forward Calls
- Manage Calls
- Time & Cost
- Show/Hide My No.
- Handsfree
- Switch to Line 2*



Connectivity

- Bluetooth
- Infrared Port
- USB Connection
- Synchronization
- Device Mgmt.
- Mobile Networks
- Data Comm.
- Internet Settings
- Streaming Settings
- Settings for Java™
- Accessories















Note

* Some menus are operator-, network- and subscription-dependent.

** Options when phone contacts are set to default, options change when SIM contacts are set to default.

*** Use the navigation key to move across tabs in submenus. For more information  13 Navigation.

Standby Icons

-  Tells you the strength of the GSM network signal.
-  GPRS network is within range and can be used.
-  EDGE network is within range and can be used.
-  Tells you the status of the battery.
-  Tells you the status of the battery charging.
-  You have missed an incoming call.
-  Call and messaging function alerts are off, alarm is still on.
-  You have received a text message.
-  You have received an email message.
-  Your phone is receiving a picture message.
-  You have received a picture message.
-  You have received a voice message.
-  You have an ongoing call.
-  You have an appointment reminder.



You have a task reminder.









The magic word is activated.





Shortcuts

You can use keypad shortcuts to quickly go to a menu, and you can use predefined navigation key shortcuts to quickly reach certain functions. You can edit the navigation key shortcuts to suit your own needs.

Using keypad shortcuts

Enter the menus by pressing  and then enter the number of the menu to which you want to go. For example, to reach the fifth menu item, press . To reach the tenth, eleventh and twelfth menu items, press ,  and  respectively. To go back to standby, press and hold .

Using navigation key shortcuts

In standby, press , ,  or  to go to a shortcuts menu, or directly to a function.

To edit a navigation key shortcut

▶ Settings ▶ the General tab ▶ Shortcuts and select which shortcut you want to edit ▶ Edit.

Phone Language

Select the language for phone menus or the languages that you may use when writing.

To change the phone language

- ▶ Settings ▶ the General tab ▶ Language ▶ Phone Language. Select a language.
- From standby, you can also press:
 - Ⓢ 8888 Ⓢ for automatic language (SIM)
 - Ⓢ 0000 Ⓢ for English.

 Most SIM cards automatically set the menu language to the country where you bought your SIM card. If not, the predefined language is English.

To select writing language

- ▶ Settings ▶ the General tab ▶ Language ▶ Writing Language.
- Scroll to the language that you want to use and mark it. ▶ Save to exit the menu.

Entering Letters and Characters

When writing messages and notes, there are two ways to enter letters and characters:

- Multitap text input
- T9™ Text Input

To enter letters using multitap input

- Press **(2)** – **(9)** repeatedly until the desired character appears on the screen.
- Press **(*)aA)** to shift between capital and lower-case letters.
- Press and hold **(0+)** – **(9)** to enter numbers.
- Press **(C)** to delete letters and numbers.
- Press **(1)** for the most common punctuation marks.
- Press **(#-?)** to add a space.

T9™ Text Input

The T9 Text Input method uses a built-in dictionary to recognize the most commonly used word for each sequence of key presses. This way, you press each key only once, even if the letter you want is not the first letter on the key.

Getting to Know Your Phone

To enter letters using T9 Text Input

- 1 For example, if you want to write the word “Jane”, press (5), (2), (6), (3).
- 2 If the word shown is the one you want, press (#→?) to accept and add a space. To accept a word without adding a space, press (⊙). If the word shown is not the one you want, press (⊙) or (⊙) repeatedly to view alternative words.
- 3 Continue writing your message. To enter a period or other punctuation marks, press (1) and then (⊙) or (⊙) repeatedly. Accept by pressing (#→?).

To add words to the T9 Text Input dictionary

- 1 While entering letters ► More ► Spell Word.
- 2 Edit the word by using multitap input. Use (⊙) and (⊙) to navigate between the letters. To delete a character, press (C). To delete the entire word, press and hold (C).

When you have edited the word ► Insert. The word is added to the T9 Text Input dictionary. Next time you enter this word using T9 Text Input, it will appear as one of the alternative words.

To switch between writing methods

Before, or while entering letters, press and hold (*a/A) to switch between writing methods.

Options when entering letters

► More to enter a list of options that offers different alternatives when writing a message.

File Manager

Files such as Pictures, Videos, Sounds, Themes, Games and Applications are saved in the folders in the phone memory. Create sub folders to move or copy files to. Unrecognized files are saved in the Other folder.

When handling files, you can select several or all files in a folder at the same time.

To use a file from the file manager

- 1 Select a file in Pictures or Sounds.
- 2 ► More ► Use As and select an option.

To move a file to a folder

- 1 ► File Manager and open a folder.
- 2 Scroll to a file, for example, a picture that you want to move ► More ► Manage Files ► Move.
- 3 Select the folder you want to move the file to, or select New Folder and name the folder ► OK.

To create a subfolder

- 1 ▶ **File Manager** and open a folder.
- 2 ▶ **More ▶ New Folder** and enter a name for the folder.
- 3 ▶ **OK** to save the folder.

To select several files

- 1 ▶ **File Manager** and select a file ▶ **More ▶ Mark ▶ Mark Several** to select several files.
- 2 Scroll and select more files by pressing **Mark**.
- 3 ▶ **More ▶ Unmark All** to remove the selection.

To select all files in a folder

- 1 ▶ **File Manager** and select a file ▶ **More ▶ Mark ▶ Mark All** to select all files.
- 2 ▶ **More ▶ Unmark All** to remove the selection.

To move or copy files to a computer

➡ *66 Transferring Files Using the USB Cable.*

File information

Items that are downloaded, or received using one of the available transfer methods, may be copyright protected. If a file is protected, you may not be able to copy or send that file. You can select to view information for the file.

Calling

Calls, contacts, voice control, call options.

Making and Receiving Calls

Before you can make or receive calls, you must turn on the phone and be within range of a network.

➡ *9 Turning on the Phone and Making Calls.*

Networks

When you turn on the phone, it automatically selects your home network if this is within range. If it is not within range, you may use another network, provided your service provider has an agreement that allows you to do so. This is called roaming.

You can select the network you want to use, or you can add a network to your list of preferred networks. You can also change the order in which networks are selected during an automatic search.

To view available network options

▶ **Settings** and use  or  to scroll to the **Connectivity** tab ▶ **Mobile Networks**.

Calling

To make a call

- 1 Enter the area code and the phone number.
- 2 ▶ **Call** to make the call.
- 3 ▶ **End Call** to end the call.

To make international calls

- 1 Press and hold  until a + sign appears.
- 2 Enter the country code, area code (without the leading zero) and phone number ▶ **Call**.

To redial a number

If a call connection fails and **Retry?** appears ▶ **Yes**.



Do not hold the phone to your ear while waiting. When the call connects, the phone gives a loud signal.

To answer or reject a call

▶ **Answer** or ▶ **Busy**.





Missed calls

If you have missed a call, **Missed calls:** appears in standby, indicating the number of missed calls.



To view the missed calls in the call list ▶ **Yes**.

If you want to view the missed calls later ▶ **No**.

To check your missed calls

- 1 From standby ▶ **Calls** and use  or  to scroll to the **Missed** tab.
- 2 Scroll  or  and ▶ **Call** to call a number.

To turn off the microphone

- 1 Press and hold  to mute the microphone during a call.
- 2 Press and hold  again to resume a conversation.



To use the loudspeaker during a call

▶ **More** ▶ **Turn On Speaker** or **Turn Off Speaker**.



Do not hold the phone to your ear while using the loudspeaker. This could damage your hearing.

To change the ear speaker volume

Press  to increase or  to decrease the ear speaker volume during a call.

Emergency Calls

Your phone supports the international emergency numbers, for example, 112, 911 and 08. These numbers can normally be used to make emergency calls in any country, with or without a SIM card inserted, if a GSM network is within range.



In some countries, other emergency numbers may also be promoted. Your service provider may therefore have saved additional local emergency numbers on the SIM card.

To make an emergency call

Enter, for example, 112 ► Call.

To view local emergency numbers

- Contacts ► Options ► Special Numbers
- Emergency Nos.

Contacts

You can save your contact information in the phone memory as contacts, or on the SIM card as names and numbers. You can choose which contacts information – **Phone Contacts** or **SIM Contacts** – is shown as default. For useful information and settings ► **Contacts** ► **Options**.

Default contact

If you select to use **Phone Contacts** as default, your contacts will show all information saved in **Contacts**. If you select **SIM Contacts** as default, the contacts will only show names and numbers saved on the SIM card.

To select default contacts

- 1 ► **Contacts** ► **Options** ► **Advanced** ► **Default Contacts**.
- 2 Select **Phone Contacts** or **SIM Contacts**.





SIM contacts

Save contacts on your SIM card with name and number.

To add a SIM contact

- 1 ► **Contacts** ► **New Contact** ► **Add**.
- 2 Enter the name ► **OK**.
- 3 Enter the number ► **OK** ► **Save**.

Phone contacts

Save contacts in the phone with names, phone numbers and personal information. You can also add pictures and ringtones to contacts. Use , ,  and  to scroll between the tabs and their information fields.

Calling

To add a phone contact

- 1 ▶ **Contacts** ▶ **New Contact** ▶ **Add**.
- 2 Enter the name ▶ **OK**.
- 3 Enter the number ▶ **OK**.
- 4 Select a number type.
- 5 Scroll between the tabs and select the fields to add information. To enter symbols such as @, ▶ **More** ▶ **Add Symbol** and select the symbol ▶ **Insert**.
- 6 When all information is entered ▶ **Save**.

To delete a contact

- ▶ **Contacts** and scroll to a contact and press .

To delete all phone contacts

- ▶ **Contacts** ▶ **Options** ▶ **Advanced**
▶ **Delete All Contacts** ▶ **Yes** and ▶ **Yes**.

Names and numbers on the SIM card are not deleted.

To automatically save names and phone numbers to the SIM card

- ▶ **Contacts** ▶ **Options** ▶ **Advanced**
▶ **Auto Save on SIM** and select **On**.

Memory status

The number of contacts you can save in the phone or on the SIM card depends on available memory.

- ▶ **Contacts** ▶ **Options** ▶ **Advanced**
▶ **Memory Status**.



Using Contacts

Contacts can be used in many ways.

Below you can see how to:

- call phone and SIM contacts.
- send contacts to another device.
- copy contacts to the phone and SIM card.
- add a picture or a ringtone to a phone contact.
- edit contacts.
- synchronize your contacts.

To call a phone contact

- 1 ▶ **Contacts** and select the contact to call.
- 2 Use  or  to select a number ▶ **Call**.

To call a SIM contact

- If **SIM Contacts** is default ▶ **Contacts** and select the name and number from the list ▶ **Call**.
- If **Phone Contacts** is default ▶ **Contacts** ▶ **Options** ▶ **SIM Contacts** and select the name and number from the list ▶ **Call**.

To send a phone contact

- ▶ **Contacts** and select a contact ▶ **More**
- ▶ **Send Contact** and select a transfer method.

To send all phone contacts

- ▶ **Contacts** ▶ **Options** ▶ **Advanced**
- ▶ **Send All Contacts** and select a transfer method.

To copy names and numbers to the SIM card

- 1 ▶ **Contacts** ▶ **Options** ▶ **Advanced**
▶ **Copy to SIM**.
- 2 Select one of the alternatives.



When copying all contacts from the phone to the SIM card, all existing SIM card information is replaced.

To copy names and numbers to phone contacts

- 1 ▶ **Contacts** ▶ **Options** ▶ **Advanced**
▶ **Copy from SIM**.
- 2 Select one of the alternatives.

To add a picture or a ringtone to a phone contact

- 1 ▶ **Contacts** and select the contact you want to add a picture or personal ringtone to ▶ **More** ▶ **Edit Contact**.
- 2 Select the relevant tab and then select **Picture** or **Ringtone** and ▶ **Add**.
- 3 Select a picture or sound and ▶ **Save**.

To edit a phone contact

- 1 ▶ **Contacts** and select a contact ▶ **More** ▶ **Edit Contact**.
- 2 Scroll to the relevant tab and select the field to edit and ▶ **Edit**.
- 3 Edit the information and ▶ **Save**.

To edit a SIM contact

- 1 If SIM contacts is default ▶ **Contacts** and select the name and number to edit. If phone contacts is default ▶ **Contacts** ▶ **Options** ▶ **SIM Contacts** and select the name and number to edit.
- 2 ▶ **More** ▶ **Edit Contact** and edit the name and number.

Calling

Synchronizing Contacts

You can back up and synchronize your contacts with a contacts application on the Web. For more information, please contact your service provider.

To synchronize contacts

- 1 ▶ **Contacts** ▶ **Options** ▶ **Sync. Contacts**.
- 2 If you have more than one account, select which account to use ▶ **Select**
➡ *61 Synchronizing* for more information.

Call List

Information about the most recently dialed, answered and missed calls are listed in separate tabs.

To call a number from the call list

- 1 ▶ **Calls** from standby and select a relevant tab.
- 2 Scroll to the name or number to call ▶ **Call**.

To add a call list number to contacts

- 1 ▶ **Calls** from standby and select a tab.
- 2 Scroll to the number to add ▶ **More**
▶ **Save Number**.
- 3 ▶ **New Contact** to create a new contact, or select an existing contact to add the number to.

To clear the call list

- ▶ **Calls** and select the **All** tab ▶ **More** ▶ **Delete All**.

Speed Dialing

Save the phone numbers that you want to reach easily in positions 1 – 9 in your phone.

To speed dial

- From standby, enter the position number ▶ **Call**.

To edit speed dialing numbers

- 1 ▶ **Contacts** ▶ **Options** ▶ **Speed Dial**.
- 2 Scroll to the position ▶ **Add** or ▶ **Replace**.

Voicemail

If your subscription includes an answering service, callers can leave a voicemail message when you cannot answer a call.



Contact your service provider for your voicemail number or for more information.

To call your voicemail service

Press and hold **(1)**. If you have not entered a voicemail number, ▶ **Yes** and enter the number.

To edit your voicemail number

► Messaging ► Settings ► Voicemail Number.

Voice Control



Manage calls with your voice by creating voice commands to:

- Voice dial – call someone by saying the name.
- Activate voice control by saying a “magic word”.
- Answer and reject calls when using a handsfree.

Before voice dialing

Activate the voice dialing function and record your voice commands. An icon appears next to a phone number that has a voice command.

To activate voice dialing and record names

- 1 ► Settings ► the General tab ► Voice Control ► Voice Dialing ► Activate ► Yes ► New Voice Cmd. and select a contact.
- 2 If the contact has more than one number, use  and  to view the numbers. Select the number to add the voice command to. Record a voice command such as “John mobile”.

- 3 Instructions appear. Wait for the tone and say the command that you want to record. The voice command is played back to you.
- 4 If the recording sounds ok ► Yes. If not ► No and repeat step 3.

To record another voice command for a contact ► New Voice Cmd. ► Add again and repeat steps 2 – 4 above.

Caller name

Hear your recorded contact name when you receive a call from that contact.

To turn the caller name on or off

► Settings ► the General tab ► Voice Control ► Play Caller Name.

Voice Dialing

Start voice dialing from standby using the phone, a portable handsfree, a Bluetooth headset or by saying your magic word.

Calling

To make a call

- 1 From standby, press and hold one of the volume buttons.
- 2 Wait for the tone and say a recorded name, for example “John mobile”. The name is played back to you and the call is connected.

To make a call with a handsfree

From standby, press and hold the handsfree button, or press the Bluetooth headset button ➡ 64 To add a Bluetooth handsfree.

The magic word

Record and use a voice command as a magic word to activate voice control without pressing any keys. The magic word can only be used with a handsfree or a Bluetooth headset.

 Choose a long, unusual word or phrase that can easily be distinguished from ordinary background speech.

To activate and record the magic word

- 1 ▶ Settings ▶ the General tab ▶ Voice Control ▶ Magic Word ▶ Activate.
- 2 Instructions appear. ▶ Continue.
Wait for the tone and say the magic word.
- 3 ▶ Yes to accept or ▶ No for a new recording.

- 4 Instructions appear. ▶ Continue and select the environments in which you want your magic word to be activated.

Voice answering

Answer or reject incoming calls by using your voice, when using a handsfree.

 You can only use a MIDI, WAV (16 kHz), EMY or IMY file as a ringtone with voice answering.

To activate voice answering and record voice answer commands

- 1 ▶ Settings ▶ the General tab ▶ Voice Control ▶ Voice Answer ▶ Activate.
- 2 Instructions appear. ▶ Continue.
Wait for the tone and say “Answer”, or another word.
- 3 ▶ Yes to accept or ▶ No for a new recording.
- 4 Instructions appear ▶ Continue. Wait for the tone and say “Busy”, or another word.
- 5 ▶ Yes to accept or ▶ No for a new recording.
- 6 Instructions appear. ▶ Continue and select the environments in which you want voice answering to be activated.

To answer or reject a call using voice commands

When the phone rings, say:

- “Answer” to connect the call or
- “Busy” to reject the call.

To edit your voice commands

- ▶ **Contacts** select the contact ▶ **More**
- ▶ **Edit Contact**. Scroll to the relevant tab.

To rerecord a voice command

- 1 ▶ **Settings** ▶ the **General** tab ▶ **Voice Control** ▶ **Voice Dialing** ▶ **Edit Names**.
- 2 Select a command ▶ **More** ▶ **Replace Voice**.
- 3 Wait for the tone and say the command.

**Forwarding Calls**

Forward calls, for example, to an answering service.



When the Restrict calls function is activated, some Forward calls options are not available.

➡ *31 Restricted Dialing.*

Your phone has the following options:

- **Always Forward** – all calls.
- **When Busy** – if a call is ongoing.
- **Not Reachable** – if turned off or unreachable.
- **No Reply** – if not answered in a specified time.

To activate a call forward

- 1 ▶ **Settings** ▶ the **Calls** tab ▶ **Forward Calls**.
- 2 Select a call type and forward option ▶ **Activate**.
- 3 Enter the phone number to forward your calls to, or press **Lookup** to find a contact ▶ **OK**.

To deactivate a call forward

Scroll to the forward option ▶ **Deactivate**.

More than one Call

Handle more than one call simultaneously.

**Call waiting service**

When activated, you hear a beep if you receive a second call.

To activate or deactivate the call waiting service

- ▶ **Settings** ▶ the **Calls** tab by using ☎ or ☎ and
- ▶ **Manage Calls** ▶ **Call Waiting**.

To make a second call

- 1 ▶ **More** ▶ **Hold** to hold the ongoing call.
- 2 Enter the number to call ▶ **More** ▶ **Call**.

Calling

Receiving a second call

When you receive a second call, you can:

- ▶ **Answer** and put the ongoing call on hold.
- ▶ **Busy** to reject and continue the ongoing call.
- ▶ **Replace Active Call** to answer and end the ongoing call.



Handling two calls

If you have calls ongoing and on hold, you can:

- ▶ **More ▶ Switch** to switch between the two calls.
- ▶ **More ▶ Join Calls** to join the two calls.
- ▶ **More ▶ Transfer Call** to connect the two calls.

You are disconnected from both calls.

- ▶ **End Call** and ▶ **Yes** to retrieve the held call.
- ▶ **End Call** twice to end both calls (operator dependent).

You cannot answer a third call without ending one of the first two calls or joining them into a conference call.

Conference Calls

Start a conference call by joining an ongoing call and a call on hold. You then put the conference on hold to call and add up to five participants or just to make another call.



There may be additional charges for calls involving multiple parties, contact your service provider for more information.

To join the two calls into a conference call

▶ **More ▶ Join Calls.**

To add a new participant

- ▶ **More ▶ Hold** to put the joined calls on hold.
- ▶ **More ▶ Add Call** and call the next person you want to include in the conference call.
- ▶ **More ▶ Join Calls.**
- Repeat steps 1 – 3 to include more participants.

To release a participant

▶ **More ▶ Release Party** and select the participant that to release from the conference call.

To have a private conversation

- ▶ **More ▶ Talk to** and select the participant that you want to talk to.
- ▶ **More ▶ Join Calls** to resume the conference call.



Two Voice Lines

Make separate calls with different phone numbers if your subscription supports alternate line service.

To select a line for outgoing calls

▶ **Settings** and use or to scroll to the **Calls** tab and select line 1 or 2.

To change the name of a line

▶ **Settings** and use or to scroll to the **Display** tab ▶ **Edit Line Names** and select the line to edit.

My Numbers

View, add and edit your own phone numbers.

To check your phone numbers

▶ **Contacts** ▶ **Options** ▶ **Special Numbers**
▶ **My Numbers** and select one of the options.

Accept Calls

Receive calls only from certain phone numbers. If the call forward option **When Busy** is activated, calls are forwarded.

To add numbers to the accepted callers list

- ▶ **Settings** and use or to scroll to the **Calls** tab ▶ **Manage Calls** ▶ **Accept Calls**
▶ **Only from List** ▶ **Edit** ▶ **Add**. Select a contact.
- To add a group of contacts to the accepted callers list ▶ **Groups** ➤ *33 Groups*.

To accept all calls

▶ **Settings** ▶ the **Calls** tab ▶ **Manage Calls**
▶ **Accept Calls** ▶ **All Callers**.



Restricted Dialing

Restrict outgoing and incoming calls. A password from your service provider is required.





If you forward incoming calls, you cannot activate some Restrict calls options.

The following calls can be restricted:

- **All Outgoing** – All outgoing calls.
- **Outgoing Intl.** – All outgoing international calls.
- **Outgoing Intl Roam** – All outgoing international calls except to your home country.
- **All Incoming** – All incoming calls.
- **Inc. When Roaming** – All incoming calls when you are abroad ➤ *21 Networks*.

Calling

To activate or deactivate a call restriction

- ▶ **Settings** and use  or  to scroll to the **Calls** tab ▶ **Manage Calls** ▶ **Restrict Calls** and select an option.
- Select **Activate** or **Deactivate**, enter your password ▶ **OK**.



Fixed Dialing

The fixed dialing function allows calls to be made only to certain numbers saved on the SIM card. The fixed numbers are protected by your PIN2.



You can still call the emergency number 911 or 112, even when the fixed dialing function is activated.

Partial numbers can be saved. For example, saving 0123456 allows calls to be made to all numbers starting with 0123456.



When fixed dialing is activated, you cannot view or manage any phone numbers saved on the SIM card.

To activate or deactivate fixed dialing

- ▶ **Contacts** ▶ **Options** ▶ **Special Numbers** ▶ **Fixed Dialing** and select **Activate** or **Deactivate**.
- Enter your PIN2 ▶ **OK** and then ▶ **OK** again to confirm.

To save a fixed number



- ▶ **Contacts** ▶ **Options** ▶ **Special Numbers**
- ▶ **Fixed Dialing** ▶ **Fixed Numbers** ▶ **New Number** and enter the information.



Call Time and Cost

During a call, the duration of the call is shown on the screen. You can check the duration of your last call, outgoing calls and the total time.





To check the call time

- ▶ **Settings** and use  or  to scroll to the **Calls** tab ▶ **Time & Cost** ▶ **Call Timers**.

Additional Calling Functions

Tone signals

Use telephone banking services or control an answering machine with tone signals during a call.

- To send the tones, press the keys  – ,  or .
- To clear the screen after a call, press .
- To turn the tones on or off during a call, ▶ **More** ▶ **Disable Tones** or **Enable Tones**.

Notepad

Enter a phone number during a call. When you end the call, the number remains on the screen to call or save in the phonebook.

- ▶ Call to call the number or press ▶ More
- ▶ Save Number and select a contact to save the number. To create a new contact and save the number ▶ New Contact.

Showing or hiding your number

If your subscription supports the Caller ID Restriction service, you can hide your phone number when making a call.

To always show or hide your phone number

- 1 ▶ Settings ▶ the Calls tab ▶ Show/Hide My No.
- 2 Select Show Number, Hide Number or Network Default.

Groups

Create a group of numbers and email addresses to send messages to several recipients at the same time ➡ *34 Messaging*. You can also use groups (with numbers) when you create accepted callers lists ➡ *31 Accept Calls*.

To create a group of numbers and email addresses

- 1 ▶ Contacts ▶ Options ▶ Groups
▶ New Group ▶ Add.
- 2 Enter a name for the group ▶ Continue.
- 3 ▶ New ▶ Add to find and select a contact number.
- 4 Repeat step 3 to add more numbers. ▶ Done.

Business Cards

Add your own business card as a contact.

To add your own business card

- ▶ Contacts ▶ Options ▶ My Business Card and add information for your business card ▶ Save.

To send your business card

- ▶ Contacts ▶ Options ▶ My Business Card
- ▶ Send My Card and select a transfer method.

Messaging

Text messaging, picture messaging, voice messaging, email, My Friends.



Your phone supports various messaging services. Contact your service provider about available services or for more information, visit www.SonyEricsson.com.

Text Messaging (SMS)

Text messages can contain simple pictures, sound effects, animations, and melodies. You can also create and use templates for your messages.



If you send a text message to a group, you will be charged for each member of that group.

Before you start

A service center number, to send and receive text messages, is provided by your service provider. It may already be set on the SIM card or you can add the number yourself.

To set a service center number

- 1 ▶ Messaging ▶ Settings ▶ Text Message ▶ Service Center.
- 2 The correct service center number is shown or if the field is empty or you want to add a new number ▶ **New Service Ctr.** and enter the number, including the international “+” sign and country code ▶ **Save.**

Sending text messages

For information about entering letters

➡ 19 *Entering Letters and Characters.*

To write and send a text message

- 1 ▶ Messaging ▶ Write New ▶ Text Message.
- 2 Write your message ▶ **Continue.**
- 3 ▶ **Enter Phone No.** for a phone recipient or ▶ **Contacts Lookup** for a number or group in Contacts or select from the last used recipients list below the send options ▶ **Send.**
- 4 To save the message without sending it, press  and ▶ **Yes** to save in **Drafts.**



*To send a message to an email address, you need to enter email settings. ➡ 59 *Settings.**

To copy and paste text in a message

- 1 While writing your message ► **More** ► **Edit** ► **Copy All** to copy all of the text in your message or ► **Copy Text** ► **Start** and use the navigation key to scroll and mark text in your message ► **End**.
- 2 ► **More** ► **Edit** ► **Paste** to paste the text.

To insert an item in a text message

- 1 While writing your message ► **More** ► **Add Item**.
- 2 Select an item type in the list that appears and then select an item to insert.

 You can convert your text message to a picture message. While writing your message ► **More** ► **To Picture Msg** and continue creating a picture message. For more information about picture messaging ► **37 Picture Messaging (MMS)**.

Receiving text messages

► **Yes** to read the message or ► **No** to read it later. When you have read the text message ► **More** for options or press  to close the message.

To call a number in a text message

Select the phone number displayed in the message, ► **Call**.

Saving and deleting text messages

Received text messages are saved in the phone memory. When the phone memory is full, delete messages or move them to the SIM card to be able to receive new messages. Messages saved on the SIM card remain until they are deleted.

To save a message

- 1 ► **Messaging** ► **Inbox** and select the message to save.
- 2 ► **More** ► **Save Message**.
- 3 ► **Saved Messages** to save on the SIM card or ► **Templates** to save the message as a template in the phone.

To save an item in a text message

- 1 While reading a message, select the phone number, picture or Web address to save ► **More**.
- 2 ► **Use** (the phone number you have selected appears) to save the phone number or ► **Save Picture** to save a picture or ► **Save Bookmark** to save a bookmark.

Messaging

To delete a message

- 1 ▶ Messaging and select a folder.
- 2 Select the message to delete and press  or ▶ More.

To save or delete several messages

- 1 ▶ Messaging and select a folder.
- 2 Select a message ▶ More ▶ Delete All Msgs to delete all messages in the folder or ▶ Mark **Several** scroll and select messages by pressing Mark or Unmark.
- 3 ▶ More ▶ Save Messages to save messages in the phone memory or on the SIM card or ▶ Delete Messages.

Long messages

The number of characters allowed in a text message depends on the language used for writing. You can send a longer message by linking two or more messages. You are charged for each of the messages linked in a long message. You may not receive all parts of a long message at the same time.



Check with your service provider for the maximum number of messages that can be linked.

To turn long messages on

- ▶ Messaging ▶ Settings ▶ Text Message
- ▶ Max. Msg. Length ▶ Max. Available.

Templates for text messages

Add a new template or save a message as a template in your phone ➔ 35 *To save a message.*

To add or use templates

- 1 ▶ Messaging ▶ Templates ▶ New Template or select a template from the list ▶ Text.
- 2 Write the message ▶ OK.
- 3 Enter a title for the message ▶ OK.

Message options

Set a default value for several message options or choose the settings each time you send a message.

To set default text message options

▶ Messaging ▶ Settings ▶ Text Message and select the options to change.

To set message options for a specific message

- 1 When the message is written and a recipient is selected ▶ More ▶ Advanced.
- 2 Select an option to change ▶ Edit and select a new setting ▶ Done.

To check the delivery status of a sent message

► **Messaging** ► **Sent Messages** and select a text message ► **View** ► **More** ► **Details**.

Picture Messaging (MMS)

Picture messages can contain camera pictures, pictures, text, sound, video clips, sound recordings, and signatures that can be sent to a mobile phone or an email address.



The sender and receiver must have subscriptions supporting picture messaging.

Before you start

If settings are not in your phone ► **59 Settings**.

Writing and sending picture messages

Add text and items. You can add and delete pages and adjust for example the timing and the background color of your message. You can also preview the message before sending it.

To write and send picture messages

- 1** ► **Messaging** ► **Write New** ► **Picture Message**.
- 2** To add text, start writing. ► **More** to select an item to add from the list that appears.
- 3** To add more text, continue writing. ► **More** to add more items to the message or to view options for the items you have already added.
- 4** When you have finished composing your message ► **Continue**.
- 5** ► **Enter Email Addr.** for an email recipient or ► **Enter Phone No.** for a phone recipient or ► **Contacts Lookup** for a number or group in **Contacts** or select from the last used recipients list below the send options ► **Send**.



When writing and editing picture messages you can use the copy and paste functionality
► **35 To copy and paste text in a message**.

To set default picture message options

► **Messaging** ► **Settings** ► **Picture Message** and select the options to change.

Messaging

Additional send options

Request a read report, a delivery report and set a priority for a specific message. You can also add more recipients to the message.

To select additional send options

- 1 When the message is created and a recipient is selected ► **More**.
- 2 ► **Add Recipient** to add recipients or
► **Edit Recipients** to edit and add recipients.
► **Edit Subject** to change the message subject or
► **Advanced** to select additional send options.

Receiving picture messages

Select how to download your picture messages and how to save items that you receive in the picture messages.

To set Automatic download

- **Messaging** ► **Settings** ► **Picture Message**
- **Auto Download** to view and select one of the following options:
 - **Always** – automatically download.
 - **Ask in Roaming** – ask to download.
 - **Not in Roaming** – do not download.
 - **Always Ask** – always ask to download.
 - **Off** – New messages appear in the **Inbox**.
Select the message and ► **View** to download.

To receive picture messages

► **Yes** to read or play the message, ► **Stop** to stop playing or reading the message, ► **Reply** to immediately reply or ► **More** to view a list of options. Press  to close the message.

To save an item in a picture message

When viewing a picture message ► **More**
► **Save Items** and select an item to save from the list that appears.

Delete picture messages

Picture messages are saved in the phone memory. When the phone memory is full, you must delete messages to be able to receive new messages
► **35 Saving and deleting text messages.**

Templates for picture messages

Add a new template or use a pre-defined template.

To add a template

- 1 ► **Messaging** ► **Templates** ► **New Template**
► **Picture Msg.**
- 2 ► **More** to add new items.
- 3 ► **Save**, enter a title ► **OK** to save the template.
- 4 Select a template from the list ► **Use**
► **Continue** and select a recipient to send the message.

To use a predefined template

- 1 ▶ **Messaging** ▶ **Templates** and select a template from the list ▶ **Use** to use the template as it is or ▶ **More** ▶ **Edit Template** to edit the template, ▶ **Save**, enter a title ▶ **OK** to save the changes.
- 2 ▶ **Continue** and select a recipient to send the message to or select a template from the list ▶ **Use** ▶ **Continue** if you have edited the template.

Voice Messages

Send and receive a sound recording as a voice message.



The sender and receiver must have a subscription supporting picture messaging.

To record and send a voice message

- 1 ▶ **Messaging** ▶ **Write New** ▶ **Voice Message**.
- 2 Record your message. ▶ **Stop** to end.
- 3 ▶ **Send** to send the message.
- 4 ▶ **Enter Email Addr.** for an email recipient or ▶ **Enter Phone No.** for a recipient phone number or ▶ **Contacts Lookup** for a number or group in **Contacts** or select from the last used recipients list below the send options.
▶ **Send**.

Receiving voice messages

▶ **Yes** to play the message or ▶ **No** if you want to play the message later. When you have listened to the voice message ▶ **More** to view a list of options. Press  to close the message.



Email

Connect to a POP3 or IMAP mail server to send and receive email messages with your phone. You can use the same email settings in your phone as in your computer email program.

Before you start

Make sure that your phone subscription supports Internet, email and data transfer and that you have registered as an email user and have email account settings in your phone. ➔ *59 Settings*.



For more information on how to enter your email settings contact your service provider or visit www.SonyEricsson.com.







Create an email account

If necessary you can manually create an email account. Make sure that you have the email account settings from your email provider available.



Some of the settings are required and some of the settings are optional.

Messaging

To enter required email account settings

- 1 ▶ Messaging ▶ Email ▶ Settings
▶ Account Settings ▶ New Account.
- 2 Enter a name for the account ▶ OK.
- 3 Press  to select **Email Address**, enter the email address ▶ OK.
- 4 Press  to select **Connect Using** and select a data account (provided by your network operator or service provider).
- 5 Press  to select **Connection Type** (POP3 or IMAP).
- 6 Press  to select **Incoming Server**, enter the server name or IP address ▶ OK.
- 7 Press  to select **Username**, enter the username for the email account ▶ OK.
- 8 Press  to select **Password**, enter the password for the email account ▶ OK.
- 9 Press  and scroll to select **Outgoing Server**, enter the server name or IP address ▶ OK.

To enter optional email account settings

Press  or  to scroll and continue to select optional settings for your email account, for example **Check Interval**.



Default email account

If you have several email accounts you can set one as default.

To set a default email account

▶ Messaging ▶ Email ▶ Settings ▶ Account Settings and select an account.

To write and send an email message

- 1 ▶ Messaging ▶ Email ▶ Write New.
- 2 ▶ Add to enter the recipient field
▶ Enter Email Addr. to enter an email address
▶ OK or ▶ Contacts Lookup to select a recipient from Contacts ▶ Select or select an email address from the last used recipients list below the send options ▶ Select.
- 3 To add more recipients select **To**, **Cc** or **Bcc** and select recipients to add. When finished selecting recipients ▶ Done.
- 4 Press  to select the subject field, type an email subject ▶ OK. To edit the subject ▶ Edit.
- 5 Press  to select the text field, write your message ▶ OK. To edit the message ▶ Edit.

- 6 Press  to select the attachment field. ▶ Add and choose the attachment type to add, for example a picture or a sound, ▶ Select to select the attachment to add ▶ More ▶ Done or **New Attachment** to add more attachments.
- 7 ▶ Continue ▶ Send.



When writing and editing email messages you can use the copy and paste functionality
 ➡ 35 To copy and paste text in a message.

To receive and read email messages

- 1 ▶ Messaging ▶ Email ▶ Inbox ▶ Send&Rec when the inbox is empty or ▶ Messaging ▶ Email ▶ Inbox ▶ More ▶ Send & Receive to download new messages.
- 2 Select a message in the inbox ▶ View to read it.

To reply to an email message

- 1 Select the message to reply in the inbox ▶ More ▶ Reply or open the message ▶ Reply.
- 2 ▶ **Include Message** to include the original message in your reply or ▶ **Write New** to exclude the original message from your reply.
- 3 Write your message in the text field ▶ OK. To edit the message ▶ Edit.
- 4 ▶ Continue ▶ Send.

To save an email address, a Web address or a phone number in an email message

- 1 Open the message and select an email address, a phone number or a Web address.
- 2 ▶ More ▶ **Save Address** to save an email address or ▶ More ▶ **Save Bookmark** to save a Web address or ▶ More ▶ **Use** ▶ **Save Number** to save a phone number.

To view or save an item in an email message

Select a message ▶ More ▶ **Save Attachment** and select an item. ▶ **Save** to save the item or ▶ More ▶ **View** to view the item.

To save an email message

Select a message ▶ More ▶ **Save Message** ▶ **Saved Email**.



The number of email messages that can be saved in the phone depends on available memory. When the phone memory is full, you must delete messages to be able to receive new messages ➡ 35 Saving and deleting text messages.

Messaging

To save several email messages

- 1 ▶ Messaging ▶ Email ▶ Inbox.
- 2 ▶ More ▶ Mark Several and scroll to select messages by pressing Mark or Unmark.
- 3 ▶ More ▶ Save Messages.

To delete an email message (POP3)

- 1 ▶ Messaging ▶ Email ▶ Inbox ▶ More.
- 2 ▶ Mark for Deletion or ▶ Mark Several and scroll to select messages by pressing ▶ Mark or Unmark. Marked messages are deleted the next time you connect to your server.

To delete an email message (IMAP4)

- 1 ▶ Messaging ▶ Email ▶ Inbox ▶ More.
- 2 ▶ Mark for Deletion or ▶ Mark Several ▶ Mark or Unmark.
- 3 ▶ More ▶ Clear Inbox. ▶ With Send & Rec. or No Send & Rec. to delete messages.

My Friends

Connect and log in to the My Friends server to communicate online with your favorite friends. If your subscription supports instant messaging and presence services, you can send and receive messages and see contact status when they are online.



Contact your service provider for more information.

To log in to your My Friends server

- ▶ Messaging ▶ My Friends ▶ Log In.

To add a contact to the list

- ▶ Messaging ▶ My Friends ▶ the Contacts tab, More ▶ Add Contact.

To send a chat message from My Friends

- 1 ▶ Messaging ▶ My Friends ▶ the Contacts tab and select a contact from the list.
- 2 ▶ Chat and type your message ▶ Send.





You can also start a chat conversation from the Conversations tab, where the chat conversations that you have started also appears.

Status

Show your status to your contacts only or change it to all users on the My Friends server.

To change your own status

► **Messaging** ► **My Friends** ► the **My Status** tab and update your status information.

Use  or  to scroll between the status fields.

Chat group

A chat group can be started by your service provider, by an individual My Friends user or by yourself. You can save chat groups by saving a chat invitation or by searching for a specific chat group.

To start a chat group

- 1 ► **Messaging** ► **My Friends** ► the **Chat Groups** tab ► **More** ► **Add Chat Group** ► **New Chat Group**.
- 2 Select contacts to invite to the chat group from your list of contacts ► **Continue**.
- 3 Enter a short invitation text ► **Continue** ► **Send**.

To add a chat group

- 1 ► **Messaging** ► **My Friends** ► the **Chat Groups** tab ► **More** ► **Add Chat Group**.
- 2 ► **By Group ID** to enter chat group ID directly or ► **Search** to search for a chat group.



The conversation history is preserved between log in and log out to let you return to chat messages from old conversations.

Area and Cell Information



Information messages may be sent to network subscribers within a certain area or cell.

To turn information on or off

► **Messaging** ► **Settings** ► **Area Info** ► **Reception** or **Cell Information**.

Imaging

Camera, video recorder, pictures.

Camera and Video Recorder

Take pictures and record video clips to view, save or send as picture messages or email attachments. If settings for picture or email messaging are not already in your phone ➔ 59 Settings.

 Do not look directly at the camera light diodes of the phone using a magnification device. Failure to comply with this warning may damage your eyes.

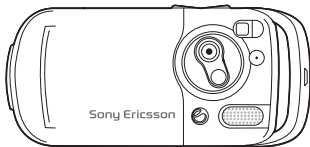

To activate the camera

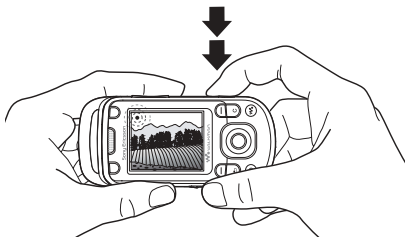

- 1 Close the phone.
- 2 From standby, press and hold  to activate the camera.

To take pictures and video clips



- 1 Use the navigation key to switch between camera and video recorder.
- 2 Press  to take a picture or start recording.
- 3 To end video recording, press again.
- 4 To deactivate the camera, press  to go back one level in the menus. Press and hold to return to standby.

 If you try to use the camera where there is a strong light source, such as direct sunlight or a lamp, the screen may black out and there may be distortion.

To use the zoom

Use the volume buttons to zoom in and out.



Zoom is not possible when picture size is set to Large (1280 x 1024).

To adjust brightness

Use the navigation key to increase or decrease brightness.

To turn on the photo light

Slide  to turn the photo light on and off.

Camera and video options

When the camera or video is activated

▶ **Settings** for the following options:

- **Switch to Video Camera** – record a video clip or **Switch to Still Camera** – take a picture.
- **Shoot Mode (camera)** – select from:
 - ▶ **Normal** – no frame
 - ▶ **Panorama** – join several pictures into one
 - ▶ **Frames** – add a frame to your picture
 - ▶ **Burst** – take a rapid sequence of pictures.
- **Shoot Mode (video)** – select from:
 - For Picture Message** or **High-quality Video**.
 - High-quality Video** is not limited to short clips.

- **Picture Size** – Large 1280x1024, Medium 640x480 or Small 160x120.
- **Video Size** – Large 176x144 or Small 128x96.
- **Turn On Night Mode** – adapt to poor lighting conditions.
- **Turn On Light** – add light to poor lighting conditions.
- **Turn On Self-Timer** – take a picture 8 – 10 seconds after pressing the camera button.
- **Effects** – select from:
 - ▶ **Off** – no effect
 - ▶ **Black & White** – no color
 - ▶ **Negative** – reversed colors
 - ▶ **Sepia** – brown tint
 - ▶ **Solarize** – overexposure.
- **White Balance** – adjust the colors to lighting conditions.
- **Picture Quality** – select from:
 - Normal** or **Fine** picture quality. Fine changes the JPEG compression and requires more space.
- **Shutter Sound** – select different shutter sounds.
- **Turn On Time and Date** – add time and date.

Imaging

Saving pictures and video clips

Take a picture or record a video clip. Files are saved automatically in the phone memory ➤ *20 File Manager.*

Take a self-portrait

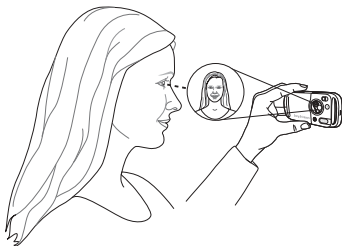

Hold the phone as shown in the illustration, so that you can see your reflection in the mirror next to the lens. Press the camera button to take the picture.

Sending pictures and video clips

Pictures and video clip recordings stored in the phone can be sent as picture messages. To exchange pictures and video clips using other transfer methods ➤ *47 Exchanging pictures.*

To send a picture or video clip

Take a picture or record a video clip ► **Send** ► **Continue** and add a recipient.

To manage a video clip or a picture

Record a video clip or take a picture ► **More** and select an option.

Transferring pictures to your computer

Using the USB cable, you can drag-and-drop camera pictures to a computer ➤ *66 Transferring Files Using the USB Cable.*

Pictures

Your phone comes with a number of pictures and animations. You can delete pictures if you want to free memory. Pictures are saved in **File Manager** ► **Pictures**. You can also:

- Use a picture as wallpaper and as a screen saver.
- Assign a picture to a contact ➤ *25 To add a picture or a ringtone to a phone contact.*
- Exchange pictures using a transfer method.

Handling pictures

View, add, edit or delete pictures in **File Manager**. The number of pictures that you can save depends on available phone memory. File types supported are, for example, GIF, JPEG, WBMP, BMP, PNG and SVG-Tiny.

To view pictures

- 1 ▶ **File Manager** ▶ **Pictures**, thumbnails appear.
- 2 ▶ **View** for a full view or ▶ **More** for options.

To display pictures in a slide show

- 1 ▶ **File Manager** ▶ **Pictures** and select a picture.
- 2 ▶ **View** ▶ **More** ▶ **Slide Show**.

To view information about a file

- 1 ▶ **File Manager** ▶ **Pictures** or **Videos**, select file.
- 2 ▶ **More** ▶ **Information**.

Using pictures

Add a picture to a contact, use it at startup, as a wallpaper in standby or as a screen saver.

Screen saver

The screen saver activates automatically when the phone is idle for a few seconds. After a few more seconds, the screen saver changes to sleep mode, to save power. Press a button to activate the screen again.

To use a picture

- 1 ▶ **File Manager** ▶ **Pictures** and select a picture.
- 2 ▶ **More** ▶ **Use As** and select an option.

To edit pictures

➡ *57 PhotoDJ™*.

Exchanging pictures

You can exchange pictures using one of the available transfer methods. Please note that you are not allowed to exchange some copyright protected material. For more information on sending and receiving pictures in messages ➡ *34 Messaging*.

To send a picture

- ▶ **File Manager** ▶ **Pictures** and select a picture
- ▶ **More** ▶ **Send** and select a transfer method.

Entertainment

To receive a picture via a transfer method

Select a transfer method and follow the instructions that appear.

 *Some phones that support pictures cannot receive picture sizes of more than 160x120. The best picture size to view on a computer is 1280x1024.*

To save a picture in a message

- 35 To save an item in a text message or
- 38 To save an item in a picture message or
- 41 To view or save an item in an email message.

Remote screen

Use a compatible Bluetooth accessory to view pictures on a remote screen such as a TV. The accessory is not included with your phone. For a complete list of compatible accessories, please visit www.SonyEricsson.com.

To connect to a remote screen

- ▶ File Manager ▶ Pictures ▶ View ▶ More
- ▶ Remote Screen ➤ 63 To add a device to your phone.

Entertainment

WALKMAN™, radio, PlayNow™, ringtones, MusicDJ™, VideoDJ™, games and more.

WALKMAN™ Player

Play music and video clips. The following file types are supported: MP3, MP4, 3GP, AAC, AMR, MIDI, IMY, EMY and WAV (16 kHz maximum sample rate). You can also use streamed files that are 3GPP compatible.

 *AMR and MIDI files are only visible and possible to play with the WALKMAN player if they are DRM-protected. You can, however, listen to other AMR and MIDI files, using the file manager.*

Install, transfer and play music

Your phone works with the Disc2Phone computer software, included on the CD that comes with the phone. Use Disc2Phone to transfer music from CDs or your computer. This way the music files are transferred in an automatic Artist-Album-Title order. Follow the procedures below to start using the WALKMAN player.

To install the USB drivers

- 1 Turn on your computer and insert the CD that came with your phone into the CD drive of your computer. If the PC Suite installation window opens, simply close it as it is not needed here.
- 2 Turn on your phone and connect the USB cable to a USB port on the computer and to the phone. The “Found New Hardware Wizards” starts on the computer.
- 3 **Computer:** Click *Install the software automatically* and click *Next*.
- 4 The wizard should find the USB software drivers automatically. Click *Finish*.
- 5 Repeat steps 3 and 4 until all five drivers are installed.

To install Disc2Phone

- 1 Turn on your computer and insert the CD that came with your phone into the CD drive of your computer. The CD starts automatically and the installation window opens.
- 2 **Computer:** Select a language and click *OK*.
- 3 **Computer:** Click *Install Disc2Phone* and follow the instructions on the screen. When the installation is complete, the Disc2Phone icon appears on the desktop of your computer.

To transfer music

- 1 Make sure your phone is turned on and connected to the computer with the USB cable.
- 2 **Computer:** Double-click the Disc2Phone icon on the computer desktop to open Disc2Phone.
- 3 **Computer:** For details on transferring music, please refer to Disc2Phone Help. Click **?** in the top right corner of Disc2Phone window.
- 4 **Computer:** You can obtain CD information (artist, track, etc.) via Disc2Phone if you are connected to the Internet while extracting music from a CD. You must also complete registration before you start.

















You cannot view the transferred files in your phone until you have removed the USB cable from the phone.

To play music and videos

- 1 ▶ **WALKMAN** or . The WALKMAN player opens.
- 2 Browse for songs by artist or track, or in playlists. You can also browse for video clips. Select a list ▶ **Open**.
- 3 Highlight a title ▶ **Play**.

WALKMAN player controls

- Press  to open the WALKMAN player or to minimize the WALKMAN player during playback.
- Press  to pause the playback. Press again to resume playing.
- Press  to go forward to the next music track or video clip.
- Press  to go back to the previous music track or video clip.
- Press and hold  or  to fast forward or rewind when playing music tracks or video clips.
- Press  or  to show a track-by-track view of the current list when playing music tracks.
- Press  or  to scroll through the playlist during playback. Files that are highlighted will not be selected until you press **Play**.
- When a video clip is playing, press  to play the video in slow motion. To resume normal playback, ► **Play**.
- When a video clip is paused, press  to play the video one frame at a time.
- Press  to go to the WALKMAN player when in the **Now Playing** view.
- Press and hold  to exit the WALKMAN player when in the **Now Playing** view.

Play/pause button

Press and hold  to start or pause music. Choose between using this button for the WALKMAN™ player or the **Radio**, or the most recently used of these.

To change the play/pause button setting

► **Settings** ► the **General** tab ► **Play/Pause Button**.

Browsing files

In the WALKMAN player, you can browse for music and video content in lists:

- **Artists** – lists of all available artists.
- **Tracks** – lists all music files (not ringtones) in your phone.
- **Playlists** – create or play your own lists of sound files.
- **Videos** – lists all video clips in your phone.

Playlists

To organize the media files that are stored in the **File Manager**, you can create playlists. Files in a playlist can be sorted by artist, title or by the order in which the files were added to the playlist. You can add a file to more than one playlist.

When you delete a playlist or a file from the playlist, it is not deleted permanently from the phone memory. You can add the file to another playlist.

To create a playlist

- ▶ **WALKMAN ▶ Playlists ▶ New Playlist**
▶ Add enter the name of the playlist ▶ OK.
- Select among the files that are available in the **File Manager**. You can add several files at a time and you can also add folders. All files in the selected folders will be added to the playlist.

To add files to a playlist

- ▶ **WALKMAN ▶ Playlists** select a playlist
▶ Open ▶ More ▶ Add Media.
- Select among the files that are available in the **File Manager**.

To remove files from a playlist

- ▶ **WALKMAN ▶ Playlists** select a playlist
▶ Open.
- Select the file and press **(C)**.

To delete playlists

- ▶ **WALKMAN ▶ Playlists** select a playlist and press **(C)**.

WALKMAN player options

- ▶ More for options:
- **Now Playing** – go to the **Now Playing** view.
 - **Add Media** – add files or folders to the playlist.
 - **Sort** – sort the playlist by artist, title or by the order in which files were added to the playlist.
 - **Delete** – remove a file from the playlist. In playlists you have created, the file is only removed from the playlist. In the **Tracks** list, the file is permanently deleted from the memory.
 - **Rename** – rename the playlist. You can only rename user-created playlists.
 - **Delete Playlist** – delete the playlist. Only the playlist is deleted; the files are still listed in the **File Manager**. You can only delete user-created playlists.
 - **Information** – view information about the current track or video.

Entertainment

- **Play Mode** – change the playback order of songs and videos. Select **Shuffle** to play the playlist files in random order, or **Loop** to restart the playlist when the last file has been played.
- **Stereo Widening** – choose between on or off.
- **Equalizer** – change settings for treble and bass when playing music in the WALKMAN player.
- **Send** – send a sound or video clip.
- **Zoom In** – zoom in on a video clip.
- **Capture Frame** – when a video clip is paused, capture a picture from the video clip.

Online music and videos

View videos and listen to music by streaming them to your phone from the Internet. If settings are not already in your phone ➔ *59 Settings*. For more information, contact your service provider or visit www.SonyEricsson.com.

To select a data account for streaming

- ▶ **Settings** ▶ the **Connectivity** tab
- ▶ **Streaming Settings** and select the data account to use.

To stream video and audio

- 1 ▶ **Internet Services** ▶ **More** ▶ **Enter Address**.
- 2 Enter or choose the address to a Web page and select a link to stream from.
The WALKMAN player opens automatically when a link is selected.

To stream saved music and videos

- 1 ▶ **Internet Services** ▶ **More** ▶ **Bookmarks**.
- 2 Select a link to stream. The WALKMAN player opens and plays the music or video.





Radio

Listen to FM radio with RDS (Radio Data System) functionality. You must connect the handsfree to your phone as it works as an antenna. The radio can also be used as an alarm signal ➔ *67 Alarm Clock*.

To listen to the radio

Connect the handsfree to your phone ▶ **Radio**.

Radio control

- **Radio** ▶ **Search** to find a broadcasting frequency.
- Press  or  to move 0.1 MHz.
- Press  or  to select preset channels.
- ▶ **More** to view options.

Saving radio channels

Save up to 20 preset channels.

To save radio channels

► Radio set frequency ► More ► Save or press and hold (0+) – (9) to save in positions 1 to 10.

To select radio channels

Use the navigation key or press (0+) – (9) to select a saved channel in positions 1 to 10.

Radio options

► More for the following options:

- **Turn Off** – turn off the radio.
- **Minimize** – return to standby to use other functions while listening.
- **Save** – save the current frequency in a position.
- **Channels** – select, rename, replace or delete a preset channel.
- **Turn On Speaker** – use the loudspeakers.
- **Auto Save** – save tuned channels in positions 1 to 20. Previously saved channels are replaced.
- **Set Frequency** – enter a frequency manually. Press (#→) to go directly to **Set Frequency**.
- **RDS** – set options for alternative frequency (AF) and station information.
- **Turn On Mono** – turn on mono sound.

To adjust the volume

► (▲) or (▼).

PlayNow™

Listen to music before you purchase and download to your phone.



This function is network- or operator-dependent. Contact your service provider for information about your subscription and PlayNow™. In some countries you may be able to purchase music tones from some of the world's top musical artists.



This service is not available in all countries.

Before you start

If settings are not in your phone ► 59 Settings.

To listen to PlayNow™ music

► PlayNow™ and select music from a list.

Downloading from PlayNow™

The total price appears when you select to download and save a music file. Your phone bill or prepay card is debited when a purchase is accepted. Terms and conditions are also provided in the phone kit.

To download a music file

- 1 When you have listened to a music file and agreed to accept the conditions ► Yes to download.
- 2 A text message is sent out to confirm payment and the file is made available to download. Music is saved in **File Manager** ► **Sounds**.

Ringtones and Melodies

Your phone comes with melodies that can be used as ringtones. You can exchange melodies using one of the available transfer methods. You are not allowed to exchange copyright-protected material.

 *If you select an MP3 file as a ringtone, you cannot use voice answering* ► 28 *Voice answering*.





To select a ringtone

► **Settings** ► the **Sounds & Alerts** tab ► **Ringtone**.

To turn the ringtone on or off

Press and hold (#-☎) from standby. All signals except the alarm signal are turned on or off.

To set the ringtone volume

- 1 ► **Settings** ► the **Sounds & Alerts** tab
► **Ring Volume** and press , , 
or  to decrease or increase the volume.
- 2 ► **Save** to save the setting.

Caller-specific ringtones

If your subscription supports Calling Line Identification (CLI) service, you can assign personal ringtones to contacts ► 25 *To add a picture or a ringtone to a phone contact*.

Sounds & alerts options

Select to use the vibrating alert or sounds.

To set the vibrating alert

► **Settings** ► the **Sounds & Alerts** tab
► **Vibrating Alert** and select from the following options:

- **On** – all the time.
- **On if in Silent** – if ring volume is off or the phone is set to silent.
- **Off** – all the time.

To set message alert

- ▶ Settings ▶ the Sounds & Alerts tab
- ▶ Message Alert and select an option.





To set the key sound

- ▶ Settings ▶ the Sounds & Alerts tab ▶ Key Sound and select an option.

MusicDJ™

Compose and edit your own melodies to use as ringtones. A melody consists of four types of tracks – **Drums**, **Basses**, **Chords**, and **Accents**. A track contains a number of music blocks. The blocks consist of pre-arranged sounds with different characteristics. The blocks are grouped into **Intro**, **Verse**, **Chorus**, and **Break**. You compose a melody by adding music blocks to the tracks.

To compose a melody

- 1 ▶ Entertainment ▶ MusicDJ™.
- 2 ▶ Insert, Copy or Paste blocks. Use , ,  or  to move between the blocks. Press  to delete a block. ▶ More to view more options.

To edit a MusicDJ™ melody

- ▶ File Manager ▶ Sounds and select the melody
- ▶ More ▶ Edit.

Exchanging MusicDJ™ melodies

Send and receive melodies using one of the available transfer methods. You are not allowed to exchange copyright-protected material.



You cannot send a polyphonic melody or an MP3 file in a text message.

To send a melody

- 1 ▶ File Manager ▶ Sounds and select a melody.
- 2 ▶ More ▶ Send and select a transfer method.

To receive a melody via a transfer method

Select a transfer method and follow the instructions that appear.

VideoDJ™

Compose and edit your own video clips by using video clips, pictures and text. You can also use trim to delete unwanted parts to shorten a video clip.

To create a video clip

- 1 ▶ Entertainment ▶ VideoDJ™.
- 2 ▶ Add ▶ Video Clip, Picture, Text or Camera ▶ Select.
- 3 To add more items press  ▶ Add.

Entertainment

To edit a selected video clip

- ▶ Edit for options:
 - **Trim** – to shorten the video clip.
 - **Add Text** – to add text to the video clip.
 - **Replace** – to select a new video clip.
 - **Delete** – to remove the video clip.
 - **Move** – to move the video clip to another position.

To edit a selected picture

- ▶ Edit for options:
 - **Replace** – to select a new picture.
 - **Duration** – to select the display time for the picture.
 - **Delete** – to remove the picture.
 - **Move** – to move the picture to another position.

To edit a selected text

- ▶ Edit for options:
 - **Edit** – to change the text.
 - **Background** – to set background.
 - **Text Color** – to set font color.
 - **Duration** – to select the display time for the text.
 - **Delete** – to remove the text.
 - **Move** – to move the text to another position.

VideoDJ™ options

- ▶ More for options:
 - **Play** – to view the video clip.
 - **Send** – to send the video clip.
 - **Soundtrack** – to add a soundtrack to the video clip.
 - **Transitions** – to set transitions between video clips, pictures and text.
 - **Save** – to save the video clip.
 - **Insert** – to insert a new video clip, picture or text.
 - **New Video** – to create a new video clip.

To edit video clips in File manager

- ▶ **File Manager** ▶ **Videos** ▶ **Open** and select file.
- ▶ **More** ▶ **VideoDJ™** ▶ **Edit**.

Sending video clips

You can send a video clip using one of the available transfer methods. Short video clips can be sent using picture messaging. If a video clip is too long, you can use the **Trim** function to make a video clip shorter.

To trim a video clip

- 1 Select a video clip from the storyboard
 - ▶ Edit ▶ Trim.
- 2 ▶ Set to set the start point and ▶ Start.
- 3 ▶ Set to set the end point and ▶ End.
- 4 Repeat steps 2 and 3 or ▶ Done.

PhotoDJ™

Edit files using PhotoDJ™ or when viewing files.

To edit and save a file

- 1 ▶ Entertainment ▶ PhotoDJ™ or ▶ File Manager
 - ▶ Pictures and select a file ▶ View
 - ▶ More ▶ Edit.
- 2 ▶ Tool and select an option.
- 3 After you have edited the selected picture
 - ▶ More ▶ Save Picture.

Sound Recorder

With the sound recorder, you can record either your own memos or calls. Recorded sounds can also be set as ringtones. Recording of a conversation is stopped if a participant ends the call. Recording of all sounds stops automatically if you receive a call.



In some countries or states it is required by law that you inform the other person before recording the call.

To record a sound

- 1 ▶ Entertainment ▶ Record Sound.
- 2 Wait until you hear a tone. When the recording starts, **Recording...** and a timer appears.
- 3 ▶ Save to end, ▶ Play to listen or ▶ More for options: Record New, Send, Rename, Delete, Recorded Sounds.

To listen to a recording

- ▶ File Manager ▶ Sounds and select a recording
- ▶ Play or ▶ Stop.

Themes

Change the appearance of the screen, for example, colors and wallpaper, by using themes. Your phone has some predefined themes that cannot be deleted if they are protected. You can create new themes and download them to your phone. For more information, visit www.SonyEricsson.com.

To select or change a theme

- ▶ File Manager ▶ Themes and select a theme.

Exchanging themes

Exchange themes using a transfer method.

Entertainment

To send a theme

- 1 ▶ **File Manager** ▶ **Themes** and select a theme.
- 2 ▶ **More** ▶ **Send** and select a transfer method.

To receive and save a theme

- 1 Use a transfer method and open the message you received the theme in.
- 2 Follow the instructions that appear on the screen.

Games

Your phone has several entertaining games. You can also download games and applications directly to the folders in your phone. Help texts are available for most games.

To start and end a game

- 1 ▶ **Entertainment** ▶ **Games**, select game ▶ **Select**.
- 2 Press and hold  to end the game.



Applications

Download and run Java™ applications. You can view information or set different permission levels.

To view info for Java™ applications

- 1 ▶ **File Manager** ▶ **Applications** or ▶ **Games**.
- 2 Select an application or a game ▶ **More** ▶ **Information**.

To set permissions for Java™ applications

- 1 ▶ **File Manager** ▶ **Applications** or ▶ **Games**.
- 2 Select an application or a game ▶ **More** ▶ **Permissions** and set options.

Java application screen size

Some Java applications are designed for a specific screen size and may not be able to adapt the application to the screen. For more information, contact the application vendor.

To set the screen size for a Java™ application

- 1 ▶ **File Manager** ▶ **Applications** or ▶ **Games**.
- 2 Select an application or a game ▶ **More** ▶ **Screen Size**.
- 3 Select an option, for example, **User-Defined** ▶ **Width:** and **Height:** to edit values.

Connectivity

Internet and email settings, synchronizing, Bluetooth, infrared, USB cable, update service.

Settings

Before you start using Internet, Messaging, My Friends or PlayNow™, settings are required in your phone.

Settings may already be entered when you buy your phone. If not, make sure you have a phone subscription that supports data transfer (GPRS).

Entering settings

You can enter settings as follows:

- Receive settings from your network operator or service provider or from *www.SonyEricsson.com*.
- Enter or edit settings manually, which requires that you have the settings from your network operator or service provider available.



For more information contact your service provider or visit www.SonyEricsson.com.

Using Internet

Browse the Internet using HTTP (Hyper Text Transfer Protocol).

To select an Internet profile

- ▶ Settings ▶ the Connectivity tab ▶ Internet Settings
- ▶ Internet Profiles and select a profile to use.

To start browsing

- ▶ Internet Services and select a service
- or ▶ Internet Services ▶ More to view options.

To stop browsing

- ▶ More ▶ Exit Browser.

Options when browsing

▶ More to view options. The menu contains the following options but may depend on the Web page you are visiting:



If you select an email address when browsing a Web page, you can send a message to that address.

▶ Go to for options:

- **Sony Ericsson** – go to the pre-defined homepage set for the current profile.
- **Bookmarks** – create, use or edit bookmarks.
- **Enter Address** – enter the address to a Web page.
- **History** – list of previously visited Web pages.
- ▶ Tools for options:
 - **Add Bookmark** – add a new bookmark.
 - **Save Picture** – save a picture.

Connectivity

- **Save Page** – save the current Web page.
- **Refresh Page** – refresh the current Web page.
- **Send Link** – send a link to the current Web page.
- **Make a Call** – make a call while browsing the Internet. ▶ **More** ▶ **End Call** to end the call and continue browsing.
- ▶ **View** for options:
 - **Full Screen** – select normal or full screen.
 - **Text Only** – select full content or text only.
 - **Zoom** – zoom in or out on the Web page.
 - **Zoom to Normal** – set zoom to default.
- ▶ **Advanced** to enter settings for the browser.
- ▶ **Exit Browser** to disconnect and go to standby.

Using bookmarks

Use, create and edit bookmarks for the browser.

To work with bookmarks

- 1 ▶ **Internet Services** ▶ **More** ▶ **Go to** ▶ **Bookmarks** and select a bookmark ▶ **More**.
- 2 Select an option.

Downloading

Download files, for example, pictures, themes, games and ringtones from Web pages.

To download from the Sony Ericsson Web page

- 1 ▶ **Internet Services** ▶ **Sony Ericsson**.
- 2 Browse the Web page, select a file to download and follow the instructions that appear.

Internet profile for Java™ applications

Some Java applications need to connect to the Internet to receive information, for example, games that downloads new levels from a game server.

Before you start

If settings are not in your phone ➡ *59 Settings*.

To select a profile for Java

- ▶ **Settings** ▶ the **Connectivity** tab
- ▶ **Settings for Java™** and select an Internet profile.

Stored information

When browsing, you can save information.



It is advisable to clear any sensitive information about previously visited Internet services. This is to avoid a security risk if your phone is misplaced, lost or stolen.

The following information can be saved:

- Cookies – improve Web page access efficiency.
- Passwords – improve server access efficiency.

To allow cookies

- ▶ Internet Services ▶ More ▶ Advanced
- ▶ the Browsing tab ▶ Allow Cookies ▶ On.

To clear cookies

- ▶ Internet Services ▶ More ▶ Advanced
- ▶ the Other tab ▶ Clear Cookies ▶ Yes.

To clear the password list

- ▶ Internet Services ▶ More ▶ Advanced
- ▶ the Other tab ▶ Clear Passwords ▶ Yes.

Internet security



Secure browsing is supported. When using an Internet profile you can turn on security in the phone.

Trusted certificates

Certain Internet services, such as banking, require certificates in your phone. Your phone may already contain certificates when you buy it or you can download new certificates.

To check certificates in your phone

- ▶ Settings ▶ the Connectivity tab ▶ Internet Settings
- ▶ Security ▶ Trusted Certificate.

Synchronizing

Synchronize phone contacts, appointments, tasks and notes via Bluetooth, the infrared port, Internet services or the USB cable included with the phone.

Synchronization software for your computer is available on the CD included with the phone. You can also visit www.SonyEricsson.com to download the software or Getting started guides for synchronization.

To select sync order for contacts

- ▶ Contacts ▶ Options ▶ Advanced
- ▶ Synchronize Order to select to order by first or last name.

Synchronization with nearby devices

Install the computer synchronization software using the CD that comes with your phone or download it from www.SonyEricsson.com. The software includes help information.

Connectivity

Remote synchronization via Internet

Synchronize online via an Internet service.

Before you start

- If settings are not in your phone ➔ *59 Settings*.
- Register a synchronization account online.
- Enter remote synchronization settings.

To enter remote synchronization settings

- 1 ▶ Organizer ▶ Synchronization ▶ New Account
▶ Yes to create a new account.
- 2 Enter a name for the new account ▶ Continue.
- 3 Enter the following:
 - **Server Address** – server URL.
 - **Username** – account username.
 - **Password** – account password.
 - **Connection** – select an Internet profile.
 - **Applications** – mark applications to synchronize.
 - **App. Settings** – select an application and enter a database name, and if required, username and password.
 - **Sync. Interval** – set how often to synchronize.

- **Remote Initiation** – select to always accept, never accept or always ask when starting from a service.
- **Remote Security** – insert a server ID and a server password.

- 4 ▶ Save to save your new account.

To start remote synchronization

- ▶ Organizer ▶ Synchronization and select an account ▶ Start.

Bluetooth™ Wireless Technology

Bluetooth makes it possible to connect wirelessly to other Bluetooth devices. You can:

- connect to several devices at the same time.
- synchronize information with other devices.
- use the remote control functionality.
- use a remote screen.
- exchange items and play multiplayer games.



We recommend a range within 33 feet (10 meters), with no solid objects in between, for Bluetooth communication.

Before you start

- Turn on Bluetooth to communicate with other devices.
- Pair the Bluetooth devices with your phone that you want to communicate with.

 Please verify whether local laws or regulations restrict the use of Bluetooth. If Bluetooth is not allowed, you must ensure that the Bluetooth function is turned off. The maximum allowed Bluetooth radio output power in the phone is automatically adjusted according to possible local restrictions. This means that the range may vary.

To turn Bluetooth on

- ▶ Settings ▶ the Connectivity tab ▶ Bluetooth ▶ Turn On.

Adding devices to your phone

Enter a passcode to set up a secure link between your phone and the device. Enter the same passcode on the device when prompted. Devices with no user interface, such as a handsfree, will have a pre-defined passcode. Consult the device user guide for more information.

 Make sure that the device you want to add has Bluetooth activated and visible.

To add a device to your phone

- 1 ▶ Settings ▶ the Connectivity tab ▶ Bluetooth ▶ My Devices ▶ New Device to search for available devices.
- 2 Select a device from the list.
- 3 Enter a passcode, if required.

To organize your list of devices

- 1 ▶ Settings ▶ the Connectivity tab ▶ Bluetooth ▶ My Devices and select a device from the list.
- 2 ▶ More to view a list of options.

Power save

Turn on to reduce power consumption by optimizing your phone for use with a single Bluetooth device. Turn off to connect with several Bluetooth devices at the same time.

To save power

- ▶ Settings ▶ the Connectivity tab ▶ Bluetooth ▶ Powersave ▶ On.

Phone name

Enter a name for your phone to be shown to other devices when found.

Connectivity

To enter a phone name

- ▶ Settings ▶ the Connectivity tab ▶ Bluetooth
- ▶ Phone Name.

Visibility

Choose to make your phone visible to other Bluetooth devices or not. If set to hide, other devices will not be able to discover your phone via Bluetooth.

To show or hide your phone

- ▶ Settings ▶ the Connectivity tab ▶ Bluetooth
- ▶ Visibility ▶ Show Phone or Hide Phone.

Exchanging items

Send or receive items using Bluetooth as the transfer method. Choose a device from the list of found devices.

To send an item

- 1 Select an item, for example ▶ **Contacts** and select a contact.
- 2 ▶ **More** ▶ **Send Contact** ▶ **Via Bluetooth**.
- 3 Select the device to send the item to ▶ **Select**.

To receive an item

- ▶ Settings ▶ the Connectivity tab ▶ Bluetooth
- ▶ Turn On. Make sure the phone is visible,
- ➡ 64 *To show or hide your phone*. When you receive an item, follow the instructions that appear.

To add a Bluetooth handsfree

- 1 ▶ Settings ▶ the Connectivity tab ▶ Bluetooth ▶ **Handsfree**.
- 2 ▶ **Yes** if you are adding a Bluetooth handsfree for the first time or ▶ **My Handsfree** ▶ **New Handsfree** ▶ **Add** if you are adding another Bluetooth handsfree. Ensure that your handsfree is in pairing mode. Consult the device user guide for more information.

Transferring sound

Transfer the sound for calls when using a Bluetooth handsfree. You can also transfer the sound for calls using the keypad.

To transfer sound when using a handsfree

During a call, ▶ **More** ▶ **Transfer Sound** and select a device.

Directing sound

Direct sound when answering a call with the phone keypad or the handsfree button.

To direct sound when answering a call with a handsfree

- 1 ▶ Settings ▶ the Connectivity tab ▶ Bluetooth ▶ Handsfree ▶ Incoming Call.
- 2 ▶ In Phone to direct to the phone
or ▶ In Handsfree to direct to the handsfree.

Remote control

Use your phone as a remote control device to control computer applications such as a media player or Microsoft® PowerPoint® presentations. Your computer must support Bluetooth HID Profile.

To select remote control

- 1 ▶ Entertainment ▶ Remote Control.
- 2 Select an application to use and the computer to connect to.

File transfer

Use a computer equipped with Bluetooth to view and transfer files in the file manager.

Use drag-and-drop functionality to:

- Transfer files between phone and computer.
- Move and organize files.
- Delete files from the phone.

Infrared Port

Use the infrared port as a transfer method with compatible devices. You can, for example, synchronize calendar items ➡ *61 Synchronizing*, and send items such as pictures.



When connecting to a computer, refer to its user documentation. Make sure that computer infrared speed is set to 115200 bps.

To turn the infrared port on

- ▶ Settings ▶ the Connectivity tab ▶ Infrared Port
- ▶ On or ▶ 10 Minutes to turn on for 10 minutes.

To connect two devices

- 1 Turn on infrared in both devices.
- 2 Make sure the infrared port on your phone is facing the infrared port on the other device with a maximum distance of 8 inches (20 cm).

Connectivity

To send an item using the infrared port (example: a contact)

- 1 Make sure that infrared in both devices is on.
 - ▶ **Contacts** and select a contact.
- 2 ▶ **More** ▶ **Send Contact** ▶ **Via Infrared**.

Transferring Files Using the USB Cable

Your phone comes with a USB cable and when you connect your phone to a computer using the USB cable, the phone memory will appear as a drive on the computer.



 *Only use the USB cable included with the phone and connect it directly to your computer.*

Use computer drag-and-drop functionality to:

- Transfer files between phone and computer
- Move and organize files.
- Delete files from the phone.

 *All phone functions, except for alarms and alerts, will be turned off during the USB connection.*

To start a USB connection with the phone turned on

- 1 Connect the USB cable to your phone and to your computer.
- 2 ▶ **Settings** and use  or  to scroll to the **Connectivity** tab.
- 3 ▶ **USB Connection** ▶ **Yes**.

To start a USB connection with the phone turned off

Connect the USB cable to your phone and to your computer.

 *Do not remove the USB cable during the file transfer since it may damage your phone memory*

To end a USB connection

- 1 Exit the USB connection on your computer. In Windows, click the **Safely Remove Hardware** icon in the taskbar, and follow the instructions.
- 2 Remove the USB cable from your phone.

More Features

Alarm clock, calendar, tasks, profiles, time and date, SIM card lock, etc.

Alarm Clock

Set an alarm for a specific time. You can also set an alarm to recur on specific days. The alarm signal is on even if the phone is set to silent or turned off. The radio can also be used as an alarm.

 *If you choose Radio as the alarm signal, please make sure that the handsfree is connected to the phone.*

To use alarms

- ▶ Organizer ▶ Alarms and select an option:
 - ▶ Alarm set a time ▶ Save.
 - ▶ Recurrent Alarm. Set a time and select days ▶ Mark ▶ Done.
 - ▶ Alarm Signal ▶ Radio or Sounds.

To snooze or turn an alarm off

To turn the alarm signal off when it rings, press any key, if radio is selected as alarm signal
 ▶ Snooze. If you do not want the alarm to be repeated ▶ Turn Off.

To cancel an alarm

▶ Organizer ▶ Alarms ▶ Alarm ▶ Turn Off.

Calendar

You can use the calendar to keep track of important meetings. The calendar can be synchronized with a computer calendar or with a calendar on the Web
 ➡ 61 Synchronizing.

Appointments

Add new appointments or use existing appointments as templates. You can also set reminders for appointments.

To add a new appointment

- 1 ▶ Organizer ▶ Calendar and select a date
 ▶ Select ▶ New Appointment ▶ Add.
- 2 Enter details and confirm each entry.

To view an appointment

- 1 ▶ Organizer ▶ Calendar and select a day (appointment days marked in bold).
- 2 Select an appointment ▶ View.

To view a calendar week

▶ Organizer ▶ Calendar ▶ More ▶ View Week.

More Features

To set when reminders should sound

- ▶ Organizer ▶ Calendar ▶ More ▶ Advanced ▶ Reminders.
- ▶ Always for a reminder to sound even when the phone is turned off or set to silent. When the reminder sounds ▶ Yes to read the appointment or ▶ No to turn off the reminder. A reminders option set in the calendar affects a reminders option set in tasks.

Navigating in your calendar

Use the navigation key to move between days or weeks. In the monthly and weekly views, you can also use the keypad as follows.

- | | |
|-----------------------|---------------------|
| C Today's date | |
| 1 Back a week | 3 Next week |
| 4 Back a month | 6 Next month |
| 7 Back a year | 9 Next year |

Calendar settings

- ▶ Organizer ▶ Calendar ▶ More to select an option:
- **View Week** – view appointments of the week.
 - **New Appointment** – add a new appointment.
 - **Change Date** – go to another date in the calendar.
 - **Advanced** – find, set reminders or select a start day for the week.
 - **Delete** – delete appointments.

Exchanging appointments

Exchange appointments using a transfer method. You can also synchronize appointments with a computer ➡ *61 Synchronizing*.

To send an appointment

Select an appointment in the list for a certain day ▶ **More** ▶ **Send** and select a transfer method.

Tasks

Add new tasks or use existing tasks as templates. You can also set reminders for tasks.

To add a new task

- ▶ Organizer ▶ Tasks ▶ New Task ▶ Add.
- ▶ Task or Phone Call.
- Enter details and confirm each entry.

To view a task

► Organizer ► Tasks and select a task ► View.

To set when reminders should sound

- 1 ► Organizer ► Tasks and select a task ► More ► Reminders.
- 2 ► Always for a reminder to sound even when the phone is turned off or set to silent. When the reminder sounds ► Yes to read the task, or to call the phone number in a phone task. ► No to turn off the reminder. A reminders option set in tasks affects a reminders option set in the calendar.

Exchanging tasks

Exchange tasks using a transfer method.

You can also synchronize tasks with a computer
 ► 61 *Synchronizing*.

To send a task

Select a task in the list of tasks for a certain day
 ► More ► Send and select a transfer method.

Notes

Make notes and save them in a list.
 You can also show a note in standby.

To add a note

► Organizer ► Notes ► New Note ► Add and enter the note ► Save.

To edit notes

- 1 ► Organizer ► Notes and a list appears.
- 2 Select a note ► More and select an option.

Exchanging notes

Exchange notes using a transfer method.
 You can also synchronize notes with a computer
 ► 61 *Synchronizing*.

To send a note

► Organizer ► Notes and select a note ► More ► Send and select a transfer method.

Timer

Your phone has a timer. When the signal rings press any key to turn it off.

To set the timer

► Organizer ► Timer and set the hours, minutes and seconds for countdown.

More Features

Stopwatch

Your phone has a stopwatch that can save several laps. The stopwatch continues to run when you answer an incoming call.

To use the stopwatch

- 1 ▶ Organizer ▶ Stopwatch ▶ Start.
- 2 ▶ Stop or ▶ New Lap if you want a lap time.
- 3 To reset the stopwatch ▶ Reset.

Light

Use the light as a flash light in dim lit environments. The light can also be used as an SOS signal.



Do not look directly at the camera light diodes of the phone using a magnification device. Failure to comply with this warning may damage your eyes.

To use the light

- 1 ▶ Organizer ▶ Light.
- 2 Choose between On for 1 Minute, On, Off or SOS.

Calculator

The calculator can add, subtract, divide and multiply.

To use the calculator

▶ Organizer ▶ Calculator.

- Press or to select \div \times $-$ $+$ $.$ $\%$ $=$
- Press to delete the figure.
- Press to enter a decimal point.

Code Memo

Save security codes, such as for credit cards, in the code memo. Set a passcode to open the code memo.

Checkword and security

To confirm that you have entered the correct passcode you must enter a checkword.

When you enter your passcode to open the code memo, the checkword is shown for a short time. If the passcode is correct, the correct codes are shown. If you enter the incorrect passcode, the checkword and the codes that are shown are also incorrect.

To open code memo for the first time

- 1 ▶ Organizer ▶ Code Memo. A message with instructions appears ▶ Continue.
- 2 Enter a four-digit passcode ▶ Continue.
- 3 Re-enter the new passcode to confirm.
- 4 Enter a checkword (maximum 15 characters) ▶ Done. The checkword can consist of both letters and numbers.

To add a new code

- 1 ▶ Organizer ▶ Code Memo and enter your passcode ▶ New Code ▶ Add.
- 2 Enter a name associated with the code ▶ Continue.
- 3 Enter the code ▶ Done.

To change the passcode

- 1 ▶ Organizer ▶ Code Memo and enter your passcode ▶ More ▶ Change Passcode.
- 2 Enter your new passcode ▶ Continue.
- 3 Re-enter the new passcode ▶ Continue.
- 4 Enter a checkword ▶ Done.

Forgot your passcode?

If you forget your passcode, you must reset the code memo.

To reset code memo

- 1 ▶ Organizer ▶ Code Memo and enter your pass code ▶ More ▶ Reset.
- 2 Reset code memo? appears ▶ Yes. The code memo is reset and all entries are cleared. The next time you enter the code memo, you must start at ➡ 71 *To open code memo for the first time.*

Profiles

Your phone has predefined profiles that are set to suit a certain environment. You can reset all profile settings to the way they were set when you bought your phone.

To select a profile

▶ Settings ▶ the General tab ▶ Profiles and select a profile.

To view and edit a profile

▶ Settings ▶ the General tab ▶ Profiles ▶ More ▶ View and Edit.



You cannot rename the normal profile.

More Features

To reset profiles

- ▶ Settings ▶ the General tab ▶ Profiles ▶ More ▶ Reset Profiles.

Time and Date

The time is always displayed in standby.

- To set the time ▶ Settings ▶ the General tab ▶ Time & Date ▶ Time. Enter the time ▶ Save.
- To set the time format ▶ Format and select an option.
- To set the date and date format ▶ Settings ▶ the General tab ▶ Time & Date ▶ Date.

SIM Card Lock

The SIM card lock protects your subscription, but not the phone itself, from unauthorized use. If you change SIM cards, your phone still works with the new SIM card.

Most SIM cards are locked at the time of purchase. If the SIM card lock is on, you have to enter a PIN (Personal Identity Number) every time you turn on your phone.

If you enter your PIN incorrectly three times in a row, the SIM card is blocked. This is indicated by the message **PIN Blocked**. To unblock it, you need to enter your PUK (Personal Unblocking Key).

Your PIN and PUK are supplied by your service provider. You can edit your PIN and select a new four- to eight-digit PIN.



If the message Codes do not match. appears when you edit your PIN, you entered the new PIN incorrectly. If the message Wrong PIN. appears, followed by Old PIN:, you entered your old PIN incorrectly.

To unblock your SIM card

- 1 When PIN Blocked appears, enter your PUK ▶ OK.
- 2 Enter a new four- to eight-digit PIN ▶ OK.
- 3 Re-enter the new PIN to confirm ▶ OK.

To edit your PIN

- 1 ▶ Settings ▶ the General tab ▶ Locks ▶ SIM Lock ▶ Change PIN.
- 2 Enter your PIN ▶ OK.
- 3 Enter a new four- to eight-digit PIN ▶ OK.
- 4 Re-enter the new PIN to confirm ▶ OK.

To turn the SIM card lock on or off

- 1 ▶ Settings ▶ the General tab ▶ Locks ▶ SIM Lock ▶ Protection and select On or Off.
- 2 Enter your PIN ▶ OK.

Phone Lock

Protect your phone against unauthorized use if it is stolen and the SIM card is exchanged. You can change the phone lock code (0000) to any four- to eight-digit personal code.

Automatic phone lock

If the phone lock is set to automatic, you do not need to enter your phone lock code until a different SIM card is inserted in the phone.

 *It is important that you remember your new code. If you should forget it, you have to hand in your phone to your local Sony Ericsson retailer.*

To set the phone lock

- 1 ▶ Settings ▶ the General tab ▶ Locks ▶ Phone Lock ▶ Protection and select an alternative.
- 2 Enter the phone lock code ▶ OK.

To unlock the phone

If the phone lock is on, enter your code ▶ OK.

To edit your phone lock code

- ▶ Settings ▶ the General tab ▶ Locks ▶ Phone Lock ▶ Change Code.

Keypad Lock

Lock the keypad to avoid dialing a number by accident.

 *Calls to the international emergency number 911 or 112 can still be made, even when the keypad is locked.*

Automatic keylock

In standby, automatic keylock means the keypad is locked a short while after you last press a key.

To set the automatic keylock

- ▶ Settings ▶ the General tab ▶ Locks ▶ Automatic Keylock.

To lock the keypad manually

Slide the lock switch or open the phone and press and hold  ▶ Lock Keys. You can still answer an incoming call and the keypad locks again after the call. The keypad remains locked until you unlock it manually.

To unlock the keypad, slide the lock switch or open the phone and press  ▶ Unlock.

Troubleshooting

Startup Screen



You can select a startup screen that will appear when you turn your phone on.

To select a startup screen

► Settings ► the Display tab ► Startup Screen and select an option.

Brightness

Adjust the brightness of the screen.

To set the brightness

► Settings ► the Display tab ► Brightness.

Troubleshooting

Why doesn't the phone work the way I want?

This chapter lists some problems that you might encounter while using your phone. Some problems require you to call your service provider, but you can easily correct most of the problems yourself.

However, if you need to hand in your phone for repair, please note that you may lose information and content that you have saved in your phone. You are advised to make a copy of such information before handing your phone in for repair.

For more support go to www.SonyEricsson.com.

I have problems with memory capacity or the phone working slowly

Possible cause: The phone memory is full or the memory contents are not properly organized.

Solution: Restart your phone every day to free memory and increase the capacity of your phone. You also have the option to do a **Master Reset**.

Some of your personal data and settings you have made will be lost when doing this

➡ 77 *Master reset.*

No battery icon appears when I start charging the phone

Possible cause: The battery is empty or has not been used for a long time.

Solution: It may take up to 30 minutes before the battery icon appears on the screen.

Some menu options appear in gray

Possible cause: A service is not activated or your subscription does not support the function.

Solution: Contact your service provider.

Possible cause: Since you cannot send themes, pictures and sounds that are copyright-protected, the **Send** menu is sometimes unavailable.

I do not understand the language in menus

Possible cause: The wrong language is set in the phone.

Solution: Change the language

➡ 19 Phone Language.

I cannot turn on the phone

Possible cause: The battery is discharged.

Solution: Recharge the battery ➡ 8 To charge the battery.

Solution: Turn the phone on with the charger attached. If the phone starts, restart the phone with no charger attached.

I cannot charge the phone or battery capacity is low

Possible cause: The charger is not properly connected to the phone.

Solution: Make sure that the charger connector clicks properly into place when connected

➡ 8 To charge the battery.

Possible cause: The battery connection is bad.

Solution: Remove the battery and clean the connectors. You can use a soft brush, cloth or q-tip, soaked with alcohol. Make sure that the battery is completely dry before you put it back. Check that the battery connectors in the phone are undamaged.

Possible cause: The battery is worn out and needs to be replaced.

Solution: Try another battery and charger for the same phone model, or visit your retailer and ask them to verify if the battery and charger are working properly.

The phone turns itself off

Possible cause: The ⓘ button has been pushed unintentionally.

Solution: Turn on the automatic keylock, or lock the keypad manually ➤ 73 Keypad Lock.

Possible cause: The battery connection is bad.

Solution: Make sure the battery is inserted correctly ➤ 8 To insert SIM card and battery.

I cannot use SMS/text messages on my phone

Possible cause: Settings are missing or incorrect.

Solution: Contact your service provider to find out the correct SMS service center setting

➤ 34 Text Messaging (SMS).

I cannot use MMS/picture messages on my phone

Possible cause: Your subscription does not include data capability.

Solution: Please contact your service provider.

Possible cause: Settings are missing or incorrect.

Solution: Go to www.SonyEricsson.com, choose your phone model, then choose “Phone setup – MMS” and follow the instructions ➤ 59 Settings.

I cannot use the Internet

Possible cause: Your subscription does not include data capability.

Solution: Please contact your service provider.

Possible cause: Internet settings are missing or incorrect.

Solution: Go to www.SonyEricsson.com, choose your phone model, then choose “Phone setup – WAP” and follow the instructions ➤ 59 Settings.

The phone cannot be detected by other users via Bluetooth

Possible cause: You have not turned Bluetooth on.

Solution: Make sure that Bluetooth is turned on and that your phone is visible to other users

➤ 64 To show or hide your phone.

I cannot synchronize or transfer data between my phone and my computer, when using the included USB cable

Possible cause: The cable has not been properly detected and installed on your computer.

The software that came with your phone has not been properly installed on the computer.

Solution: Go to www.SonyEricsson.com, choose your phone model, then choose “Product information” – “Getting started”. The guide

“Synchronizing the phone with a computer” contains installation instructions and a troubleshooting guide, that may assist you in solving the problem.

Master reset

The changes that you have made to settings and the content that you have added or edited, will be deleted.

To reset the phone

- 1 ▶ Settings ▶ the General tab ▶ Master Reset.
- 2 ▶ Reset Settings or ▶ Reset All.
- 3 When instructions appear ▶ Continue.

Error messages

Insert SIM

Possible cause: There is no SIM card in the phone or you may have inserted it incorrectly.

Solution: Insert a SIM card ➡ 8 To insert SIM card and battery.

Possible cause: The SIM card connectors need cleaning.

Solution: Remove the SIM card and clean it. Also check that the card is not damaged in a way that may prevent connection to the phone connectors. In that case, contact your service provider for a new SIM card.

Insert correct SIM card.

Possible cause: The phone is set to work only with certain SIM cards.

Solution: Verify whether you are using the correct service provider SIM card for your phone.

Wrong PIN./Wrong PIN2.

Possible cause: You have entered your PIN or PIN2 incorrectly.

Solution: Enter the correct PIN or PIN2 ▶ Yes ➡ 72 SIM Card Lock.

PIN Blocked/PIN2 blocked

Possible cause: You have entered your PIN or PIN2 code incorrectly three times in a row.

Solution: To unblock ➡ 72 SIM Card Lock.

Codes do not match.

Possible cause: The two codes that you have entered do not match.

Solution: When you want to change a security code (for example your PIN) you have to confirm the new code by entering exactly the same code again. ➡ 72 SIM Card Lock.

Troubleshooting

No netwk coverage

Possible cause: Your phone is not receiving any radio signal, or the received signal is too weak.

Solution: Contact your service provider and make sure that the network has coverage where you are. If so, try to do a new search.

Possible cause: The SIM card is not working properly.

Solution: Insert your SIM card in another phone. If you still get the same or a similar message, please contact your service provider.

Possible cause: The phone is not working properly.

Solution: Insert your SIM card in another phone.

If this works, it is probably the phone that is causing the problem. Please contact the nearest Sony Ericsson service location.

Emerg. Calls Only

Possible cause: You are within range of a network, but you are not allowed to use it. However, in an emergency, some service providers allow you to call the emergency number 911 or 112.

Solution: You have to move to get a signal that is strong enough. Contact your service provider and make sure your subscription is ok ➡ *23 Emergency Calls.*

Phone locked.

Possible cause: The phone is locked.

Solution: To unlock the phone ➡ *73 Phone Lock.*

Phone lock code:

Possible cause: The phone lock code is required.

Solution: Enter the phone lock code. Your phone comes with the default phone lock code 0000 ➡ *73 Phone Lock.*

PUK blocked.

Possible cause: You entered your PUK (personal unblocking key) code incorrectly 10 times in a row.

Solution: Contact your service provider.

Charging, Non-standard battery.

Possible cause: The battery that you are using is not a Sony Ericsson approved battery.

Solution: ➡ *82 Battery use and care.*

Important Information

Sony Ericsson Consumer Web site, safe and efficient use, warranty, declaration of conformity.

Sony Ericsson Consumer Web site

On www.SonyEricsson.com there is a support section where help and tips are only a few clicks away. Here you find the latest computer software updates and tips on how to use your product more efficiently.

Accessible Solutions/Special Needs

For phones sold in the U.S., you can use your TTY terminal with your Sony Ericsson mobile phone (with the necessary accessory). For information on Accessible Solutions for individuals with special needs call the Sony Ericsson Special Needs Center at 877-878-1996 (TTY) or 877-207-2056 (voice), or visit the Sony Ericsson Special Needs Center at www.SonyEricsson-snc.com.

Guidelines for Safe and Efficient Use

Please read this information before using your mobile phone.



Recommendations

- Always treat your product with care and keep it in a clean and dust-free place.
- Do not expose your product to liquid or moisture or humidity.
- Do not expose your product to extreme high or low temperatures.
- Do not expose your product to open flames or lit tobacco products.
- Do not drop, throw or try to bend your product.
- Do not close your product with an object inserted between keypad and display; this may damage your product.
- Do not paint your product.
- Do not use your product near medical equipment without requesting permission.
- Do not use your product when in, or around aircraft, or areas posted "turn off two-way radio".
- Do not use your product in an area where a potentially explosive atmosphere exists.



Important Information

- Do not place your product or install wireless equipment in the area above your car's air bag.
- Do not attempt to disassemble your product. Only Sony Ericsson authorized personnel should perform service.



Antenna

Only use an antenna that has been specifically designed by Sony Ericsson for your mobile phone. Use of unauthorized or modified antennas could damage your mobile phone and may violate regulations, causing loss of performance and SAR levels above the recommended limits (see below).

Efficient use

Hold your mobile phone as you would any other phone. Do not cover the top of the phone when in use, as this affects call quality and may cause the phone to operate at a higher power level than needed, thus shortening talk and standby times.

Radio frequency (RF) exposure and SAR

Your mobile phone is a low-power radio transmitter and receiver. When it is turned on, it emits low levels of radio frequency energy (also known as radio waves or radio frequency fields).

Governments around the world have adopted comprehensive international safety guidelines,

developed by scientific organizations, e.g. ICNIRP (International Commission on Non-Ionizing Radiation Protection) and IEEE (The Institute of Electrical and Electronics Engineers Inc.), through periodic and thorough evaluation of scientific studies. These guidelines establish permitted levels of radio wave exposure for the general population. The levels include a safety margin designed to assure the safety of all persons, regardless of age and health, and to account for any variations in measurements.

Specific Absorption Rate (SAR) is the unit of measurement for the amount of radio frequency energy absorbed by the body when using a mobile phone. The SAR value is determined at the highest certified power level in laboratory conditions, but the actual SAR level of the mobile phone while operating can be well below this value. This is because the mobile phone is designed to use the minimum power required to reach the network.

Variations in SAR below the radio frequency exposure guidelines do not mean that there are variations in safety. While there may be differences in SAR levels among mobile phones, all Sony Ericsson mobile phone models are designed to meet radio frequency exposure guidelines.

For phones sold in the U.S., before a phone model is available for sale to the public, it must be tested and certified to the FCC that it does not exceed the limit established by the government-adopted

requirement for safe exposure. The tests are performed in positions and locations (that is, at the ear and worn on the body) as required by the FCC for each model. For body worn operation, this phone has been tested and meets FCC RF exposure guidelines when the handset is positioned a minimum of 15 mm from the body without any metal parts in the vicinity of the phone or when used with the original Sony Ericsson body worn accessory intended for this phone. Use of other accessories may not ensure compliance with FCC RF exposure guidelines.

A separate leaflet with SAR information for this mobile phone model is included with the material that comes with this mobile phone. This information can also be found, together with more information on radio frequency exposure and SAR, on:
www.sonyericsson.com.

Driving

Please verify whether local laws and regulations restrict the use of mobile phones while driving or require drivers to use handsfree solutions. We recommend that you use only Sony Ericsson handsfree solutions intended for use with your product. Please note that because of possible interference to electronic equipment, some vehicle manufacturers forbid the use of mobile phones in their vehicles unless a handsfree kit with an external antenna supports the installation.

Always pay full attention to driving and pull off the road and park before making or answering a call if driving conditions so require.

Personal medical devices

Mobile phones may affect the operation of cardiac pacemakers and other implanted equipment. Please avoid placing the mobile phone over the pacemaker, e.g. in your breast pocket. When using the mobile phone, place it at the ear opposite the pacemaker. If a minimum distance of 15 cm (6 inches) is kept between the mobile phone and the pacemaker, the risk of interference is limited. If you have any reason to suspect that interference is taking place, immediately turn off your mobile phone. Contact your cardiologist for more information.

For other medical devices, please consult the manufacturer of the device.

CHILDREN

DO NOT ALLOW CHILDREN TO PLAY WITH YOUR MOBILE PHONE OR ITS ACCESSORIES. THEY COULD HURT THEMSELVES OR OTHERS, OR COULD ACCIDENTALLY DAMAGE THE MOBILE PHONE OR ACCESSORY. YOUR MOBILE PHONE OR ITS ACCESSORY MAY CONTAIN SMALL PARTS THAT COULD BE DETACHED AND CREATE A CHOKING HAZARD.



Important Information

Disposal of old electrical & electronic equipment

This symbol on the product or on its packaging indicates that this product shall not be treated as household waste.



Instead it shall be handed over to the applicable collection point for the recycling of electrical and electronic equipment. By ensuring this product is disposed of correctly, you will help prevent potential negative consequences for the environment and human health, which could otherwise be caused by inappropriate waste handling of this product. The recycling of materials will help to conserve natural resources. For more detailed information about recycling of this product, please contact your local city office, your household waste disposal service or the shop where you purchased the product.

Power supply

Connect the AC power adapter only to designated power sources as marked on the product. Make sure the cord is positioned so that it will not be subjected to damage or stress. To reduce risk of electric shock, unplug the unit from any power source before attempting to clean it. The AC power adapter must not be used outdoors or in damp areas. Never alter the cord or plug. If the plug will not fit into the outlet, have a proper outlet installed by a qualified electrician.

Emergency calls

Mobile phones operate using radio signals, which cannot guarantee connection under all conditions. Therefore you should never rely solely upon any mobile phone for essential communications (e.g. medical emergencies).

Emergency calls may not be possible on all cellular networks or when certain network services and/or mobile phone features are in use. Check with your local service provider.

Battery use and care

We recommend that you fully charge the battery before you use your mobile phone for the first time. The battery can only be charged in temperatures between +5°C (+41°F) and +45°C (+113°F).

A new battery or one that has not been used for a long time could have reduced capacity the first few times it is used.

The talk and standby times depend on the actual transmission conditions when using the mobile phone. If the mobile phone is used near a base station, less power is required and talk and standby times are prolonged.

- **Warning!** May explode if disposed of in fire.
- Use only Sony Ericsson branded original batteries and chargers intended for use with your mobile phone. Other chargers may not charge sufficiently or may

produce excessive heat. Using other batteries and chargers could be dangerous.

- Do not expose the battery to liquid.
- Do not let the metal contacts on the battery touch another metal object. This could short-circuit and damage the battery.
- Do not disassemble or modify the battery.
- Do not expose the battery to extreme temperatures, never above +60°C (+140°F). For maximum battery capacity, use the battery at room temperature.
- Turn off your mobile phone before removing the battery.
- Keep out of children's reach.
- Use the battery for the intended purpose only.
- Do not allow the battery to be put into the mouth. Battery electrolytes may be toxic if swallowed.



Disposing of the battery

Please check local regulations for disposal of batteries or call your local Sony Ericsson Call Center for information.

The battery should never be placed in municipal waste. Use a battery disposal facility if available.

End User License Agreement

This wireless device ("Device") contains software owned by Sony Ericsson Mobile Communications AB ("Sony Ericsson"), its affiliated companies and its third party suppliers and licensors ("Software").

As user of this Device, Sony Ericsson grants you a non-exclusive, non-transferable, non-assignable license to use the Software solely in conjunction with the Device on which it is installed. Nothing herein shall be construed as a sale of the Software to a user of this Device.

You shall not reproduce, modify, distribute, reverse engineer, decompile, otherwise alter or use any other means to discover the source code of the Software or any component of the Software. For avoidance of doubt, you are at all times entitled to transfer all rights and obligations to the Software to a third party, solely together with the Device with which you received the Software, provided always that such third party agrees in writing to be bound by these rules.

You are granted this license for a term of the useful life of this Device. You can terminate this license by transferring all your rights to the Device on which you have received the Software to a third party in writing. If you fail to comply with any of the terms and conditions set out in this license, it will terminate with immediate effect.

Important Information

Sony Ericsson and its third party suppliers and licensors are the sole and exclusive owner of and retain all rights, title and interest in and to the Software. Sony Ericsson, and, to the extent that the Software contains material or code of a third party, such third party, shall be entitled third party beneficiaries of these terms.

The validity, construction and performance of this license shall be governed by the laws of Sweden. The foregoing shall apply to the full extent permitted by, when applicable, statutory consumer rights.

Limited Warranty

Sony Ericsson provides this Limited Warranty for your mobile phone and original accessory delivered with your mobile phone (hereinafter referred to as "Product").

Should your Product need warranty service, please return it to the dealer from whom it was purchased, or contact your local Sony Ericsson Call Center (national rates may apply) or visit www.SonyEricsson.com to get further information.

Our warranty

Subject to the conditions of this Limited Warranty, Sony Ericsson warrants this Product to be free from defects in design, material and workmanship at the time of its original purchase by a consumer, and for a subsequent period of one (1) year.

What we will do

If, during the warranty period, this Product fails to operate under normal use and service, due to defects in design, materials or workmanship, Sony Ericsson authorized distributors or service partners, in the country/region* where you purchased the Product, will, at their option, either repair or replace the Product in accordance with the terms and conditions stipulated herein.

Sony Ericsson and its service partners reserve the right to charge a handling fee if a returned Product is found not to be under warranty according to the conditions below.

Please note that some of your personal settings, downloads or other information may be lost when your Sony Ericsson Product is repaired or replaced. At present Sony Ericsson may be prevented by applicable law, other regulation or technical restrictions from making a backup copy of certain downloads. Sony Ericsson does not take any responsibility for any lost information of any kind and will not reimburse you for any such loss. You should always make backup copies of all the information stored on your Sony Ericsson Product such as downloads, calendar and contacts before handing in your Sony Ericsson Product for repair or replacement.

Conditions

- 1** The warranty is valid only if the original proof of purchase issued to the original purchaser by an, for this Product, Sony Ericsson authorized dealer, specifying the date of purchase and serial number**, is presented with the Product to be repaired or replaced. Sony Ericsson reserves the right to refuse warranty service if this information has been removed or changed after the original purchase of the Product from the dealer.
- 2** If Sony Ericsson repairs or replaces the Product, the repaired or replaced Product shall be warranted for the remaining time of the original warranty period or for ninety (90) days from the date of repair, whichever is longer. Repair or replacement may involve the use of functionally equivalent reconditioned units. Replaced parts or components will become the property of Sony Ericsson.
- 3** This warranty does not cover any failure of the Product due to normal wear and tear, or due to misuse, including but not limited to use in other than the normal and customary manner, in accordance with the Sony Ericsson instructions for use and maintenance of the Product. Nor does this warranty cover any failure of the Product due to accident, software or hardware modification or adjustment, acts of God or damage resulting from liquid. A rechargeable battery can be charged and discharged hundreds of times. However, it will eventually wear out – this is not a defect. When the talk time or standby time is noticeably shorter, it is time to replace your battery. Sony Ericsson recommends that you use only batteries and chargers approved by Sony Ericsson. Minor variations in display brightness and color may occur between phones. There may be tiny bright or dark dots on the display. These are called defective pixels and occur when individual dots have malfunctioned and cannot be adjusted. Two defective pixels are deemed acceptable. Minor variations in camera image appearance may occur between phones. This is nothing uncommon and is not regarded as a defective camera module.
- 4** Since the cellular system on which the Product is to operate is provided by a carrier independent from Sony Ericsson, Sony Ericsson will not be responsible for the operation, availability, coverage, services or range of that system.
- 5** This warranty does not cover Product failures caused by installations, modifications, or repair or opening of the Product performed by a non-Sony Ericsson authorized person.
- 6** The warranty does not cover Product failures which have been caused by use of accessories or other peripheral devices which are not Sony Ericsson branded original accessories intended for use with the Product.

Important Information

- 7 Tampering with any of the seals on the Product will void the warranty.
- 8 THERE ARE NO EXPRESS WARRANTIES, WHETHER WRITTEN OR ORAL, OTHER THAN THIS PRINTED LIMITED WARRANTY. ALL IMPLIED WARRANTIES, INCLUDING WITHOUT LIMITATION THE IMPLIED WARRANTIES OF MERCHANTABILITY OR FITNESS FOR A PARTICULAR PURPOSE, ARE LIMITED TO THE DURATION OF THIS LIMITED WARRANTY. IN NO EVENT SHALL SONY ERICSSON OR ITS LICENSORS BE LIABLE FOR INCIDENTAL OR CONSEQUENTIAL DAMAGES OF ANY NATURE WHATSOEVER, INCLUDING BUT NOT LIMITED TO LOST PROFITS OR COMMERCIAL LOSS; TO THE FULL EXTENT THOSE DAMAGES CAN BE DISCLAIMED BY LAW.

Some countries/states do not allow the exclusion or limitation of incidental or consequential damages, or limitation of the duration of implied warranties, so the preceding limitations or exclusions may not apply to you.

The warranty provided does not affect the consumer's statutory rights under applicable legislation in force, nor the consumer's rights against the dealer arising from their sales/purchase contract.

*EUROPEAN UNION (EU)

If you have purchased your Product in an EU country you can have your Product serviced, under the conditions set out above, within the warranty period in any EU country where an identical Product is sold by an authorized Sony Ericsson distributor. To find out if your Product is sold in the EU country you are in, please call the local Sony Ericsson Call Center. Please observe that certain services may not be possible elsewhere than in the country of original purchase, for example due to the fact that your Product may have an interior or exterior which is different from equivalent models sold in other EU countries. It may not be possible to repair SIM-locked Products.

** In some countries/regions additional information is requested. If so, this is clearly shown on the valid proof of purchase.

FCC Statement

This device complies with Part 15 of the FCC rules. Operation is subject to the following two conditions:

- (1) This device may not cause harmful interference, and
- (2) This device must accept any interference received, including interference that may cause undesired operation.



Declaration of Conformity

We, **Sony Ericsson Mobile Communications AB**
of Nya Vattentorget

S-221 88 Lund, Sweden

declare under our sole responsibility that our product

Sony Ericsson type AAF-1052021-BV

and in combination with our accessories, to which this
declaration relates is in conformity with the appropriate
standards 3GPP TS 51.010-1, EN 301489-7,
EN 300328, EN 301489-17 and EN 60950, following
the provisions of, Radio Equipment and
Telecommunication Terminal Equipment directive
99/5/EC with requirements covering EMC directive
89/336/EEC, and Low Voltage directive **73/23/EEC**.

Lund, August 2005

CE0682

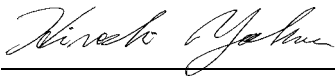

*Hiroshi Yoshioka, Head of Product Business Unit
GSM/UMTS*

We fulfill the requirements of the R&TTE Directive
(**99/5/EC**).

Index

A

- alarm clock 67
- animations 46
- answering service 26
- applications 58
- appointments 67
- automatic redialing 22

B

- battery
 - inserting and charging 8
 - use and care 82
- Bluetooth™ wireless technology 62
- business cards 33

C

- calculator 70
- calendar 67–68
- call forward 29
- call list 26
- call numbers in message 35
- call time 32
- call waiting 29

88

- caller-specific ringtones 54
- calls
 - accepting 31
 - answering and rejecting 22
 - emergency 23
 - handling two calls 30
 - international 22
 - making and receiving 11, 22
 - making notes during 33
 - missed 22
 - putting on hold 29
 - recording 57
 - restricting 31
- camera 44–46
- chinese input 20
- code memo 70
- conference calls 30
- contacts
 - adding phone contacts 24
 - default contacts 23
 - groups of 33
 - synchronizing 61

D

- date 72
- declaration of conformity 87
- delivery status 37
- Disc2Phone 48
 - installing 49
- display, brightness 74
- downloading files 60

E

- effects, camera 45
- email 39–42
- entering letters
 - multitap input 19
 - T9™ Text Input 20

F

- file manager 20
- fixed dialing 32

G

- games 58
- groups 33

H

handsfree 64
help texts, in phone 15
hiding number 33

I

icons 18
infrared port 65–66
instant messaging *See* My friends 42
Internet
 bookmarks 60
 cookies and passwords 61
 security and certificates 61
 settings 59

K

key sound 55
keypad lock 73
keys and buttons 13–15

L

language 19, 75
light 70
locks
 phone 73
 SIM card 72
long messages 36

M

magic word 28
melodies 54–55
memory status
 phone contacts 24
 SIM contacts 24
menu overview 16
messages
 alert 55
 area and cell information 43
 delivery status 37
 email 39
 picture 37, 39
 text 34
 voice 39

microphone 22
MMS *See* picture messages 37, 39
multitap input
 entering letters 19
music
 transferring 49
MusicDJ™ 55
My Friends 42
my numbers 31

N

navigating menus 13
networks 21
night mode, camera 45
notepad 33
notes 69

O

on if silent 54
open/close, phone 10

Index

P

phone

- assembly 7
- language 19
- overview 12

photo light 45

PhotoDJ™ 57

picture messages 37–38

pictures

- edit 57
- screen saver 47
- sizes 45

PIN code

- changing 72
- entering 10
- unlocking 9

PlayNow™ 53

profiles 71–72

PUK 9, 72

R

remote control 65

resetting phone 77

ringtones 54–55

S

safety guidelines 79

screen saver 47

self-portrait 46

sending

- appointments and tasks 68
- business cards 33
- melodies and ringtones 55
- notes 69
- pictures 47
- themes 57–58

settings

- display brightness 74
- email 39
- Internet 59
- Java™ 60

setup wizard 9, 10

shortcuts 18

SIM card

- contact numbers 23
- copying to/from 25
- inserting 8
- lock and unblock 72

SMS *See* text messages 34

SOS *See* emergency numbers 23

sound recorder 57

sound, transferring and directing 64

sounds & alerts 54

special needs 79

speed dialing 26

startup screen 47, 74

stereo handsfree headset 11

stopwatch 70

streaming media 52

synchronizing 61–62

T

T9™ Text Input

- add words 20
- entering letters 20

tasks 68–69

templates 36, 38

text messages 34–37

themes 57–58

time 72

timer 69

transferring

- music 49

TTY 79
 Phone Number 79
turning on/off
 Bluetooth 63
 infrared port 65
 phone 10
 phone lock 73
 ringtones, melodies 54
 SIM lock protection 72

U

unlock SIM card 72
USB cable 46, 66
USB drivers
 installing 49

V

vibrating alert 54
video clips 44, 48
video recorder 44–46
VideoDJ™ 55
voice answering 28
voice control 27–29
voice dialing 27

voice messages 39
voicemail 26
volume, ear speaker 22

W

WALKMAN™ player 48–52
wallpaper 47
WAP *See* Internet 59
warranty 84
writing languages 19

Z

zoom
 camera 45
 video clip 52
 Web page 60



Sony Ericsson

www.SonyEricsson.com

Sony Ericsson Mobile Communications AB, SE-221 88 Lund, Sweden
AE/LZT 123 1785 R1A. Printed in XXXXX

This is the Internet version of the user's guide. © Print only for private use.